



Isolated Measurement Systems

TIVM1, TIVM1L, TIVM05, TIVM05L, TIVM02, TIVM02L Datasheet



The Tektronix TIVM Series IsoVu™ Measurement System offers a galvanically isolated measurement solution for accurately resolving high bandwidth, differential signals up to ± 50 Vpk in the presence of large common mode voltages with the best in class common mode rejection performance across its bandwidth.

Features and benefits

- Bandwidths from DC to 1 GHz
- 1 Million to 1 (120 dB) Common Mode Rejection up to 100 MHz
- 10,000 to 1 (80 dB) Common Mode Rejection at 1 GHz
- 2,000 V Common Mode Voltage
- Up to ± 50 V Differential (DC + pk AC)
- Output Clamping
- Safety Certified

Applications

- Half/Full Bridge designs using GaN, SiC, IGBTs
- Floating Measurements
- Power Converter Design
- Power Device Evaluation
- Switching Power Supply Design
- Inverter Design
- Motor Drive Design
- Electronic Ballast Design
- EMI
- ESD
- Current shunt measurements
- Remote probing capability

Product Description

The TIVM Series (IsoVu) products can be used on most Tektronix oscilloscopes with the TekVPI interface and on MSO/DPO70K series oscilloscopes with the TCA-VPI50 adapter. IsoVu utilizes an electro-optic sensor that converts the electrical signal from the sensor tip cables to an optical signal, which electrically isolates the device-under-test from the oscilloscope. IsoVu incorporates four separate lasers, an optical sensor, five optical fibers, and sophisticated feedback and control techniques. The sensor head, which connects to the test point, has complete electrical isolation and is powered over one of the optical fibers (No batteries required). IsoVu is an ideal solution for users making the following measurements:

- Differential measurements in the following conditions:
 - Complete galvanic isolation is required
 - High common mode voltage
 - High frequency common mode interference
 - High frequency measurements
- Measurements in high EMI environments
- EMI compliance testing
- ESD testing

Specifications

All specifications are guaranteed unless noted otherwise. All specifications apply to all models unless noted otherwise.

Overview

Characteristic	TIVM1/TIVM1L	TIVM05/TIVM05L	TIVM02/TIVM02L
Bandwidth/Rise time (Typical)	1 GHz / \leq 350 ps	500 MHz / \leq 700 ps	200 MHz / \leq 1.8 ns
Fiber cable length	TIVM1: 3 m (9.8 ft) TIVM1L: 10 m (32.8 ft)	TIVM05: 3 m (9.8 ft) TIVM05L: 10 m (32.8 ft)	TIVM02: 3 m (9.8 ft) TIVM02L: 10 m (32.8 ft)

Attenuation

Five sensor tip cables with the following attenuation options:

Sensor tip cable	1X Range on the controller	2X Range on the controller
IVTIP1X, 1X Sensor tip cable	1X (\pm 1)	2X (\pm 2)
IVTIP5X, 5X Sensor tip cable	5X (\pm 5)	10X (\pm 10)
IVTIP10X, 10X Sensor tip cable	10X (\pm 10)	20X (\pm 20)
IVTIP25X, 25X Sensor tip cable	25X (\pm 25)	50X (\pm 50)
IVTIP50X, 50X Sensor tip cable	50X (\pm 50)	100X (\pm 100)

Common mode voltage

2 kVpk CAT I from DC - 1 GHz (1000 V, CAT II)

Common mode rejection ratio (Typical)

Sensor tip cable/ adapter	DC	100 MHz	200 MHz	500 MHz	1 GHz
IVTIP1X, 1X Sensor tip cable	> 120 dB	120 dB	110 dB	100 dB	90 dB
IVTIP5X, 5X Sensor tip cable	> 120 dB	120 dB	110 dB	100 dB	90 dB
IVTIP10X, 10X Sensor tip cable	> 120 dB	120 dB	110 dB	100 dB	90 dB
IVTIP25X, 25X Sensor tip cable	> 120 dB	110 dB	100 dB	100 dB	90 dB
IVTIP50X, 50X Sensor tip cable	> 120 dB	100 dB	90 dB	90 dB	80 dB
MMCX-to 0.1 in (2.54 mm) square pin adapter with sensor tip cable.	> 120 dB	70 dB	60 dB	40 dB	30 dB
MMCX-to 0.062 in (1.57 mm) square pin adapter with sensor tip cable.	> 120 dB	70 dB	60 dB	40 dB	30 dB

Differential input voltage (Typical)

IVTIP1X	\pm 1 V (DC + Peak AC)
IVTIP5X	\pm 5 V (DC + Peak AC)
IVTIP10X	\pm 10 V (DC + Peak AC)
IVTIP25X	\pm 25 V (DC + Peak AC)
IVTIP50X	\pm 50 V (DC + Peak AC)

Maximum non-destructive voltage (Typical)

IVTIP1X	4.3 Vpk, 3 V _{RMS}
IVTIP5X	21.5 Vpk, 12 V _{RMS}

IVTIP10X	43 V _{pk} , 16 V _{RMS}
IVTIP25X	107.5 V _{pk} , 25 V _{RMS}
IVTIP50X	200 V _{pk} , 35 V _{RMS}

Differential input impedance (Typical)

Sensor tip cable	Resistance	Capacitance
IVTIP1X	50 Ω	N.A.
IVTIP5X	250 Ω	< 1 pF
IVTIP10X	500 Ω	< 1 pF
IVTIP25X	1.25 kΩ	< 1 pF
IVTIP50X	2.5 kΩ	< 1 pF

Common mode input impedance (Typical)

Input resistance	Galvanically isolated through the fiber optic connection
Input capacitance ¹	< 2 pF

Input offset range (Typical)

IVTIP1X	±2 V
IVTIP5X	±10 V
IVTIP10X	±20 V
IVTIP25X	±50 V
IVTIP50X	±100 V

DC Gain accuracy ±3%

Propagation delay

3 meter fiber cable	35 ns ±5 ns
10 meter fiber cable	68 ns ±7 ns

Laser certification

CLASS I LASER PRODUCT

This product complies with 21 CFR 1040.10 and 1040.11 except for deviations pursuant to Laser Notice No. 50, dated June 24, 2007.

¹ The capacitance between the sensor head and a reference plane. The sensor head is placed six inches (15.25 cm) above the reference plane.

Ordering information

Models

TIVM1	Tektronix IsoVu 1 GHz Medium Voltage with 3 m cable
TIVM1L	Tektronix IsoVu 1 GHz Medium Voltage with 10 m cable
TIVM05	Tektronix IsoVu 500 MHz Medium Voltage with 3 m cable
TIVM05L	Tektronix IsoVu 500 MHz Medium Voltage with 10 m cable
TIVM02	Tektronix IsoVu 200 MHz Medium Voltage with 3 m cable
TIVM02L	Tektronix IsoVu 200 MHz Medium Voltage with 10 m cable

TIVM series

Standard accessories

016-2108-xx	IsoVu product carrying case, soft case
016-2110-xx	IsoVu accessories carrying case, soft case
003-1946-xx	Solder aid for 0.062-inch (1.57 mm) pitch square pins (0.016 - 0.018-inch (0.4 - 0.46 mm) square pin installation tool)
IVTIP5X	5X Sensor tip cable
IVTIP25X	25X Sensor tip cable
003-1947-xx	5/16-inch SMA wrench/driver tool
131-9717-xx	Probe tip adapter (blue), MMCX to 0.1-inch (2.54 mm) square pin (0.025-inch (0.635 mm) square pins)
131-9677-xx	Probe tip adapter (white), MMCX to 0.062-inch (1.57 mm) square pin (0.016 - 0.018-inch (0.4 - 0.46 mm) square pins)
020-3169-xx	DUT Interface pin kit with (qty. 20) 0.018-inch (0.46 mm) round solder-in pins
352-1171-xx	Flexible tripod with quick release
344-0693-xx	Flexible tripod feet, 3 each
352-1170-xx	Probe tip tripod support with living hinge, 2 each
071-3495-xx	User manual (English)
—	Certificate of traceable calibration

Translated manuals can be downloaded as pdf files on your local Tektronix Web site.

Recommended accessories

IVTIP1X	1X Sensor tip cable
IVTIP10X	10X Sensor tip cable
IVTIP50X	50X Sensor tip cable

Supported oscilloscopes

The measurement system can be used with the following Tektronix oscilloscopes. For oscilloscopes not included in this list, contact your local Tektronix representative.

- MDO3000 series
- MSO/DPO4000B series
- MDO4000B/C series
- MSO/DPO5000B series
- DPO7000C series

In addition to the above oscilloscopes, the measurement system can also be used with the following oscilloscopes with a TCA-VPI50 adapter.

- MSO/DPO70000C series
- MSO/DPO70000DX series
- DPO70000SX series

Options

Service options

Opt. C3	Calibration Service 3 Years
Opt. C5	Calibration Service 5 Years
Opt. D1	Calibration Data Report
Opt. D3	Calibration Data Report 3 Years (with Opt. C3)
Opt. D5	Calibration Data Report 5 Years (with Opt. C5)
Opt. G3	Complete Care 3 Years (includes loaner, scheduled calibration, and more)
Opt. R3	Repair Service 3 Years (including warranty)
Opt. R5	Repair Service 5 Years (including warranty)

Probes and accessories are not covered by the oscilloscope warranty and Service Offerings. Refer to the datasheet of each probe and accessory model for its unique warranty and calibration terms.

Datasheet

ASEAN / Australasia (65) 6356 3900
Belgium 00800 2255 4835*
Central East Europe and the Baltics +41 52 675 3777
Finland +41 52 675 3777
Hong Kong 400 820 5835
Japan 81 (3) 6714 3086
Middle East, Asia, and North Africa +41 52 675 3777
People's Republic of China 400 820 5835
Republic of Korea +822 6917 5084, 822 6917 5080
Spain 00800 2255 4835*
Taiwan 886 (2) 2656 6688

Austria 00800 2255 4835*
Brazil +55 (11) 3759 7627
Central Europe & Greece +41 52 675 3777
France 00800 2255 4835*
India 000 800 650 1835
Luxembourg +41 52 675 3777
The Netherlands 00800 2255 4835*
Poland +41 52 675 3777
Russia & CIS +7 (495) 6647564
Sweden 00800 2255 4835*
United Kingdom & Ireland 00800 2255 4835*

Balkans, Israel, South Africa and other ISE Countries +41 52 675 3777
Canada 1 800 833 9200
Denmark +45 80 88 1401
Germany 00800 2255 4835*
Italy 00800 2255 4835*
Mexico, Central/South America & Caribbean 52 (55) 56 04 50 90
Norway 800 16098
Portugal 80 08 12370
South Africa +41 52 675 3777
Switzerland 00800 2255 4835*
USA 1 800 833 9200

* European toll-free number. If not accessible, call: +41 52 675 3777

For Further Information. Tektronix maintains a comprehensive, constantly expanding collection of application notes, technical briefs and other resources to help engineers working on the cutting edge of technology. Please visit www.tek.com.

Copyright © Tektronix, Inc. All rights reserved. Tektronix products are covered by U.S. and foreign patents, issued and pending. Information in this publication supersedes that in all previously published material. Specification and price change privileges reserved. TEKTRONIX and TEK are registered trademarks of Tektronix, Inc. All other trade names referenced are the service marks, trademarks, or registered trademarks of their respective companies.



22 Jun 2016 51W-60778-0

www.tek.com

Tektronix[®]

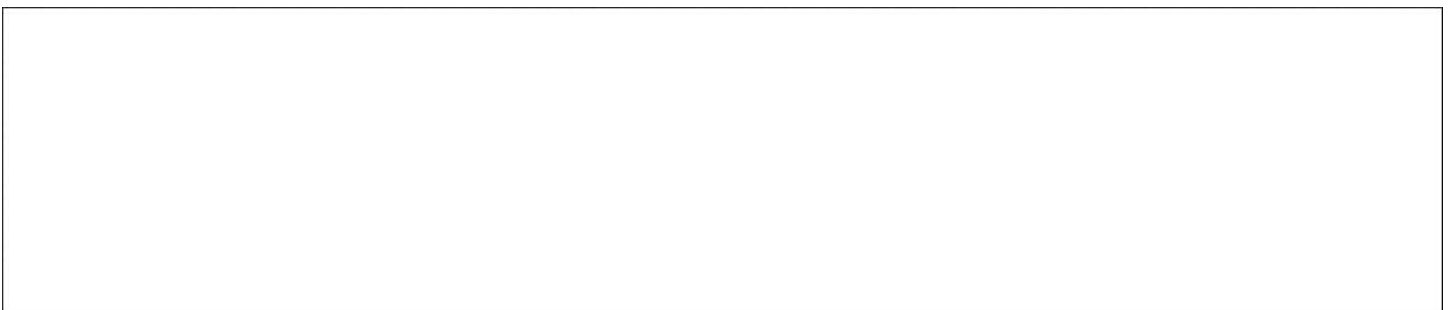

IsoVu™ Optically Isolated DC - 1 GHz Measurement System Offers >120 dB CMRR with 2kV Common Mode Range

Introduction

This white paper describes the optically isolated measurement system architecture trademarked IsoVu™. IsoVu offers complete galvanic isolation and is the industry's first measurement solution capable of accurately resolving high bandwidth, low voltage differential signals in the presence of large common mode voltages. The stand out feature of IsoVu™ is its best in class common mode rejection across the entire bandwidth.



Figure 1: IsoVu Measurement System

The target audience for this paper includes anyone making the following measurements:

- Differential measurements in the following conditions:
 - Complete galvanic isolation is required
 - High common mode voltage
 - High frequency common mode interference
- Measurements in high EMI environments
- EMI compliance testing
- ESD testing
- Remote measurements up to 10 meters away from the device under test without loss in measurement performance

Measurement Pain Points and Sources of Error

Voltage is the difference of electrical potential between two points in a circuit, and any voltage measurement between two points is considered a differential voltage measurement. Even when using a passive probe with a ground clip it is considered differential because it's measuring the difference in potential between the probe tip and ground. However, the "ground" potential at the oscilloscope's input BNC connector is not necessarily the same as the "ground" in the circuit being measured. In other words, "ground is not ground".

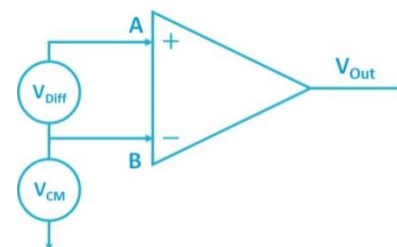

Figure 2: Differential Measurement

IsoVu™ Optically Isolated DC - 1 GHz Measurement System Offers >120 dB CMRR with 2kV Common Mode Range

The objective of the differential measurement is to get a perfect representation of V_{A-B} as shown in *Figure 2*. Unfortunately, the perfect representation of V_{A-B} is not possible due to some of the following causes:

- Common mode voltage or common mode interference
- Radiated emissions
- Ground loops
- Measurement system inaccuracy
 - Insufficient bandwidth
 - Insufficient common mode rejection capability
 - Insufficient sensitivity

The Common Mode Problem

Users making differential measurements with a traditional differential probe often fail to realize the trade-offs and limitations when measuring in an environment where common mode voltage or common mode interference is present. The capabilities of today's differential probes derate over frequency for the following specifications:

- Common Mode Voltage (CMV)
- Common Mode Rejection Ratio (CMRR)
- Common Mode Loading

Voltage Derating over Frequency

All differential probes have a common mode voltage rating with some probes specifying a common mode voltage range of thousands of volts. However, the listed specification is generally true only at DC and low frequencies. The probe's common mode voltage capability is derated as the frequency of the signal increases, which severely limits the common mode voltage capability at higher frequencies.

An example of this derating is the common mode voltage plot of Keysight's N2890A 100 MHz high voltage differential probe shown in *Figure 3*. Although the voltage rating of the probe is 1 kV_{rms} at low frequencies, the probe's capabilities start to roll off at 2 MHz and this probe is only capable of 20 V_{rms} at 100 MHz. This is a limitation that is rarely understood and users often fail to realize that a probe such as this one with a 1 kV_{rms} rating is only capable of 20 V_{rms} at maximum bandwidth. This misunderstanding can result in measurement inaccuracy and damaged equipment.

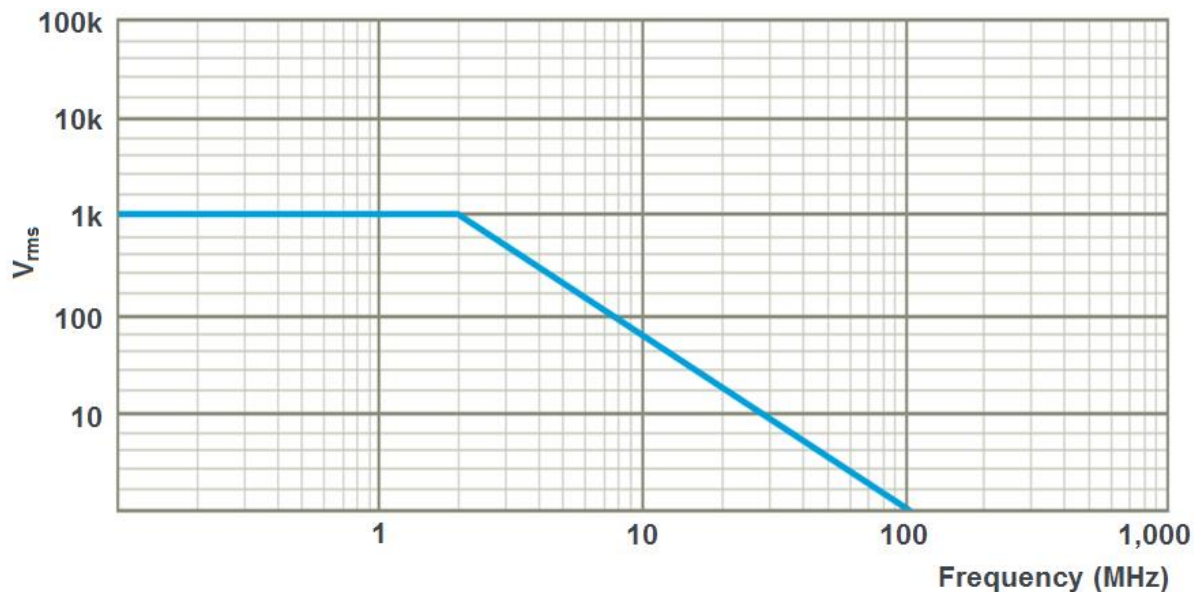

Figure 3: Common Mode Voltage Derating Plot for Keysight N2890A Differential Probe

IsoVu™ Optically Isolated DC - 1 GHz Measurement System Offers >120 dB CMRR with 2kV Common Mode Range

CMRR Derating over Frequency

Common-mode rejection ratio (CMRR) is a differential probe's ability to reject any signal that is common to both test points in a differential measurement ($V_A - V_B$). CMRR is a key figure of merit for differential probes and amplifiers, and it is defined by:

$$\text{CMRR} = | A_{\text{Diff}} / A_{\text{CM}} |$$

where:

A_{Diff} = the voltage gain for the difference signal

A_{CM} = the voltage gain for common-mode signal

Ideally, A_{Diff} should be large and A_{CM} would be zero, resulting in an infinite CMRR. In practice, a CMRR of at least -80 dB (10,000:1) is considered quite good. An amplifier that has long been considered best in class is the LeCroy DA1855A. In *Figure 4*, the DA1855A's CMRR exceeds the -80 dB level at low frequencies up to a few MHz. However, the CMRR capability of this amplifier quickly derates and is only capable of a mere -20 dB or 10:1 at 100 MHz. What this means is that a common-mode input signal of 10 volts at 100 MHz will induce a 1 V error signal in the differential measurement. It should be noted that the plot in *Figure 4* is for the amplifier only. When using "matched" probes with the amplifier the performance is further degraded.

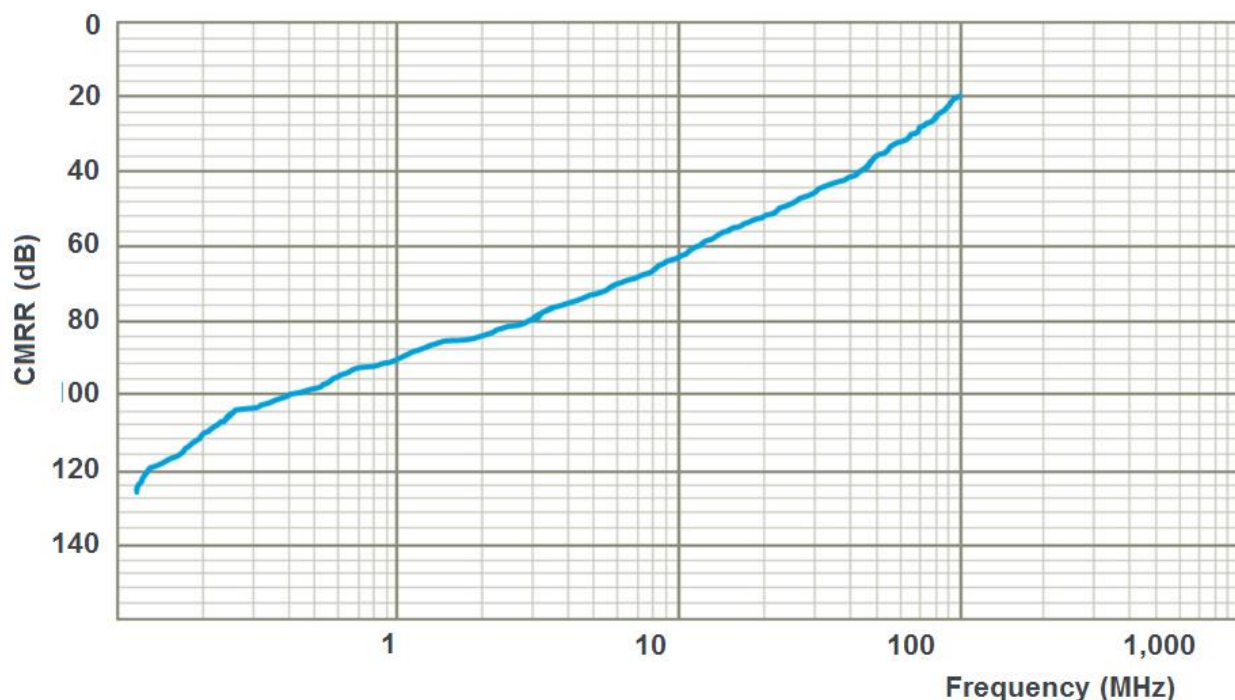

Figure 4: CMRR Plot for LeCroy DA1855A Differential Amplifier

Common Mode Loading Derating over Frequency

Although the common mode DC input impedance of a typical probe can be very high, as the signal frequency increases the common mode impedance is dominated by the common mode capacitance to ground. At higher frequencies, the capacitive loading becomes a matter of increasing concern by distorting the waveform and increasing the load on the DUT. As shown in *Figure 5*, the Keysight N2819A probe has a large common mode input impedance at DC and low frequencies but the impedance drops to 40 Ohms at 1 GHz.

IsoVu™ Optically Isolated DC - 1 GHz Measurement System Offers >120 dB CMRR with 2kV Common Mode Range

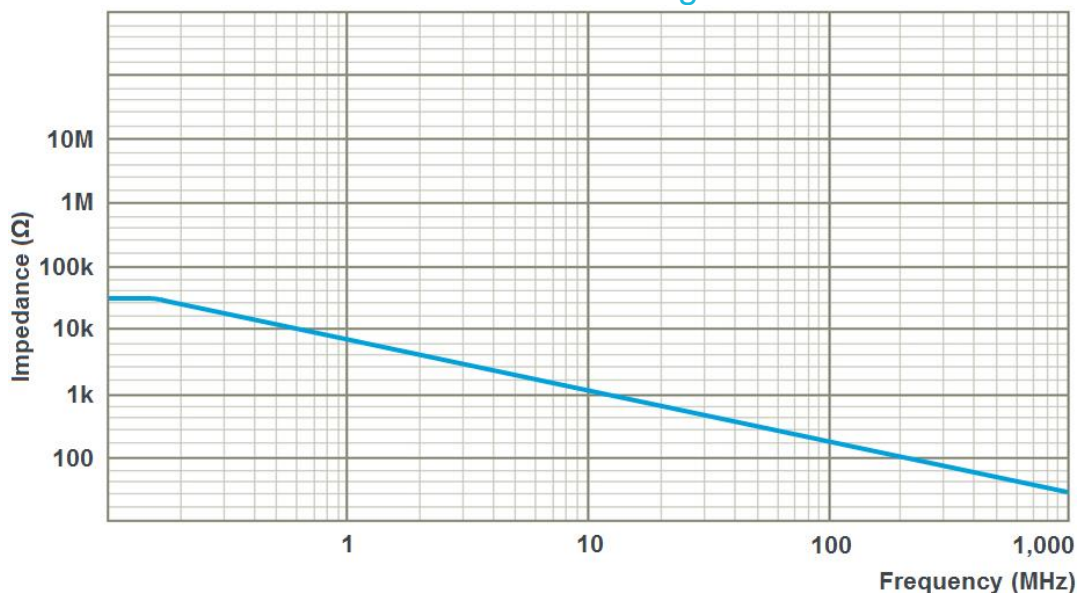

Figure 5: Common Mode Impedance Derating Curve for Keysight N2819A Differential Probe

Users need to pay careful attention to all three of these factors which can have a negative impact on the measurement results. The ideal measurement system would not have these limitations and deratings described above.

The IsoVu Solution to the Common Mode Problem

IsoVu Common Mode Voltage

IsoVu architecture with galvanic isolation provides common mode withstand voltages of > 2000 V_{peak} across its frequency range with NO derating. The electrical limitation for an optically isolated solution such as IsoVu is many thousands of volts given IsoVu's 3 meter and 10 meter fiber optic lengths. Because IsoVu achieves galvanic isolation through its fiber optic connection, the only limitation in its common mode voltage rating is due to safety certification standards. Where the Keysight N2790A plot shows degraded performance over frequency, IsoVu has no derating over frequency.

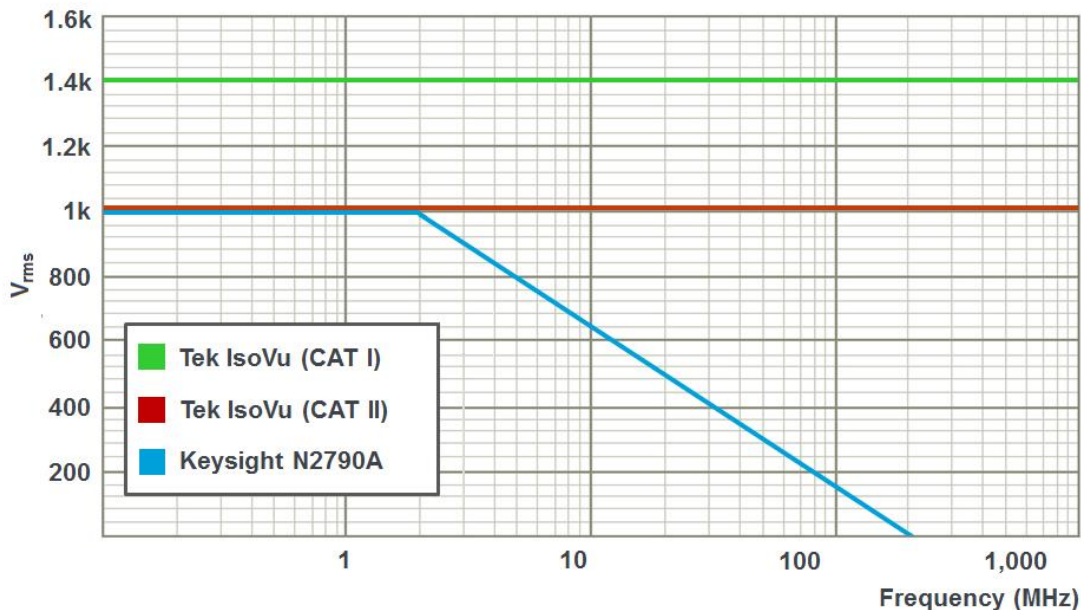

Figure 6: IsoVu Common Mode Voltage Derating Curve

IsoVu™ Optically Isolated DC - 1 GHz Measurement System Offers >120 dB CMRR with 2kV Common Mode Range

IsoVu CMRR

IsoVu achieves exceptional CMRR over the entire operating range due to the combination of complete galvanic isolation and its IsoVu sensor head architecture. It should be noted that the data in *Figure 7* is representative of the actual measured CMRR because the measurement was limited by the sensitivity of the test system and the noise floor of the VNA. For comparison, the LeCroy DA1855A without probes at 100 MHz has a CMRR value of 20 dB (10:1) while IsoVu offers 120 dB (1 Million:1).

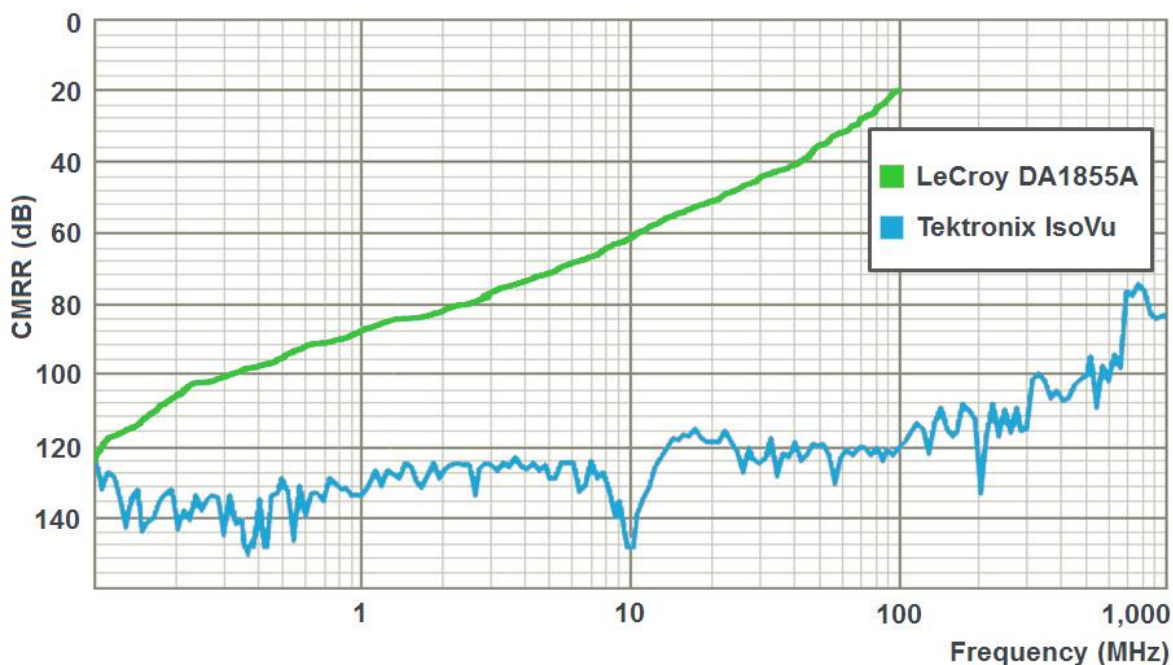

Figure 7: IsoVu CMRR Plot

IsoVu Common Mode Loading

Since the IsoVu system has no electrical connection from the sensor head to ground or the rest of the test system, the only common mode loading is the parasitic capacitance from the sensor head to the environment. For example, placing the sensor head 6" (15.25 cm) above a reference plane would result in ~2 pF of parasitic capacitance between the sensor head and the reference plane.

IsoVu Theory of Operation

IsoVu utilizes an electro-optic sensor to convert the input signal to optical modulation, which electrically isolates the device-under-test from the oscilloscope. IsoVu incorporates four separate lasers, an optical sensor, five optical fibers, and sophisticated feedback and control techniques. The sensor head, which connects to the test point, has complete electrical isolation and is powered over one of the optical fibers. *Figure 8* shows the block diagram.

IsoVu™ Optically Isolated DC - 1 GHz Measurement System Offers >120 dB CMRR with 2kV Common Mode Range

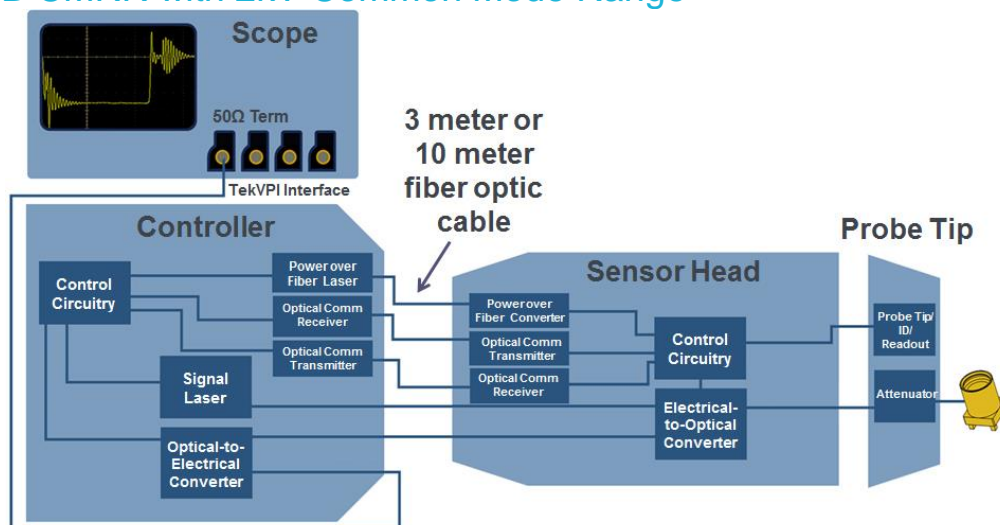

Figure 8: IsoVu Block Diagram

Controller

The Controller connects to the scope via a coax cable and TekVPI Comp Box. The Controller is powered directly from the TekVPI Interface. The Controller Box provides the following functions:

- TekVPI Interface communication/power link with host oscilloscope
- Microcontroller and support circuitry
- Power Over Fiber laser/driver
- Signal Laser, signal laser driver (adjustable output power) and thermo-electric cooler driver
- Optical Communication (RX/TX)
- Transimpedance Amplifier (TIA) and supporting circuitry

Sensor Head

The Sensor Head contains an electrical-to-optical sensor that converts the electrical signal from the DUT to an optical signal to be sent to the controller via the optical fiber link. The Sensor Head also contains a DC/LF feedback loop that measures the DUT signal and sends it to the controller for analysis. This allows the system to correct for a variety of drifts and offset errors in the system. The Sensor Head is powered by an optical link.

Tip Cables

The Tip Cables connect the DUT to the sensor head. A variety of Tip Cables with different



Figure 9: Tip Cable

attenuations will be provided and the customer will select which attenuation to use based on the signal being measured. The Tip Cable will connect to the Sensor Head via an SMA connector. Each tip cable will include readout encoding that allows the Sensor Head to communicate the attenuation factor to the scope to display the correct vertical scale factor.

Five different tip cables will be available with attenuation ranges from 1X to 50X and corresponding differential ranges from $\pm 1V$ to $\pm 50V$. Since the sensor head input is a 50 Ohm SMA connector, users can connect directly to the sensor head with an SMA cable with a differential range of $\pm 1V$. This input structure affords users the opportunity to build custom interfaces to the DUTs.

IsoVu™ Optically Isolated DC - 1 GHz Measurement System Offers >120 dB CMRR with 2kV Common Mode Range

IsoVu Connectivity Options

Traditional high voltage differential solutions ship with robust accessories such as alligator clips or hook clips that have been suitable for higher voltage environments but have the trade-off of lower signal fidelity. With increasing power densities and higher performance requirements, traditional accessories have become less useful. IsoVu offers multiple connectivity options to maximize both performance and convenience.

A reference design that can accommodate an MMCX connector as a test point will get the greatest performance and convenience using the IsoVu solution. With an MMCX connector at the end of the tip cable, IsoVu will easily snap into MMCX connectors on a reference design board as shown in *Figure 10*.

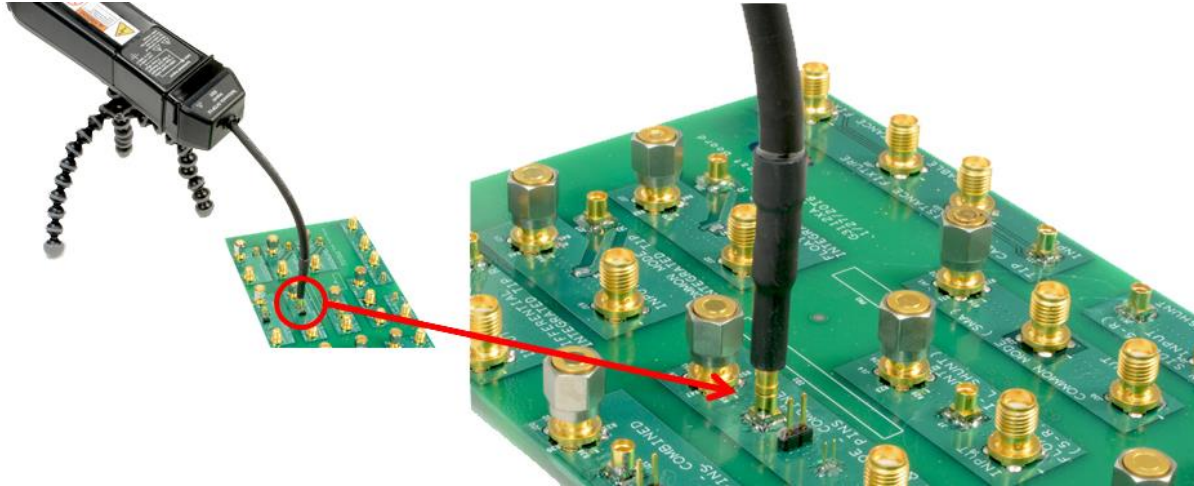

Figure 10: IsoVu Connectivity to a DUT

With a reference design that cannot accommodate an MMCX connector, the IsoVu measurement solution includes square pin adapters which will fit over square pins soldered onto the test board.

IsoVu Banner Specifications

- Resolve <math><50\text{V}</math> high speed differential voltages in the presence of large common mode voltages (up to $2\text{ kV}_{\text{peak}}$)
- Bandwidth from DC to 1GHz
- Unmatched Common-Mode Rejection
 - 120 dB (1 Million to 1) from DC – 100 MHz
 - 80 dB (10,000 to 1) at 1 GHz
- Galvanically isolated measurement system architecture
- 3 m and 10 m separation between sensor head and controller for remote measurements and to reduce susceptibility of test equipment from DUT
- Resolve a 10 mV signal in 1X mode with a 1X tip and down to 5 mV using high res mode or averaging

Additional IsoVu Features

Output Clamping

IsoVu offers a unique selectable output clamping feature. When enabled, this feature will limit the output voltage swing of the IsoVu measurement system into the scope's input and will allow the user to increase the vertical sensitivity on the scope without the oscilloscope being overdriven or saturating. Overdriving the oscilloscope is a common user trap which results in the waveform being distorted or rolled off.

IsoVu™ Optically Isolated DC - 1 GHz Measurement System Offers >120 dB CMRR with 2kV Common Mode Range

Input Referred Offset

Input referred offset extends the effective dynamic range of the measurement system by allowing the user to offset the DC component of their signal.

Long Cable Option

IsoVu will ship with either a 3 meter or 10 meter fiber optic cable solution between the sensor head and the controller allowing the user to remotely locate the device under test from the test system. Both cable options meet the full set of specifications.

Conclusion

Accurate differential measurements rely on a measurement system's bandwidth, rise time, common mode voltage, common mode rejection capability, and the ability to connect to smaller test points to characterize devices that are shrinking in size and increasing in performance. Despite these requirements, advancements in test and measurement for power testing, EMI testing, ESD testing, and remote measurement capability have been minimal at best and have not kept pace with changing requirements. While differential voltage probes have had modest performance gains in regard to bandwidth, these probes have failed to make any substantial improvements in regard to common mode rejection, and connectivity. IsoVu is a leap forward in technology and is the only solution with the required combination of high bandwidth, high common mode voltage, and high common mode rejection to enable these differential measurements.

Copyright © 2016, Tektronix. All rights reserved. Many Tektronix products are covered by U.S. and foreign patents, issued and pending. Information in this publication supersedes that in all previously published material. Specification and price change privileges reserved. TEKTRONIX and TEK are registered trademarks of Tektronix, Inc. All other trade names referenced are the service marks, trademarks or registered trademarks of their respective companies.

03/16 51W-60485-0