

Highpowered and programmable Switching Power supply IT6500 Series Programming Guide



Model: IT6512/IT6513/IT6512A/IT6513A/IT6522A/IT6502D
/IT6512D/ IT6532A/IT6533A/IT6523D

Version: 1.0

Safety

Please do not install replacement parts in the instrument, or perform any unauthorized modification. Please send the instrument to our company's maintenance department for maintenance, to ensure its security features.

Please refer to the manual for specific information warning or precautions to avoid personal injury or equipment damage.

There is no part that the operator can maintain. If maintenance service is required, please contact a trained service personnel.

Security regulation

To prevent electric shock, non-authorized personnel is strictly not allowed to open the machine.

This equipment is strictly prohibited for use in life support systems or any other device with security requirements.

We cannot accept responsibility for any direct or indirect financial damage or loss of profit that might occur when using the electronic load.

Certification and Quality Assurance

IT6512 programmable DC power supply fully meet all of the technical specification in the manual.

Warranty

Our Company give one year warranty for the materials and manufacturing of the product since the date of shipment.

Warranty Service

For the warranty service or repair the product, the product must be returned to the designated maintenance units. Return the product to us for warranty service, you should pre-pay the one-way Freight to the maintenance department. and our company is responsible for the return shipping cost.

If products are returned from other countries for maintenance service, then you should pay all freight, duties and other taxes.

Limitation of Warranty

The guarantee does not apply to the damage caused by the following conditions:

Improper or inadequate maintenance to the products by customer;

Customers use their own software or interface;

Unauthorized modification or misuse;

Operate this product not in the specified environment, or at the wrong place configuration and maintenance.

Damage from Customer self-installation of circuit, or defects due to customers use their products.

Product model or serial number of the fuselage has been altered, deleted, removed or made illegible;

Damage caused by accidents including but not limited to lightning, water, fire, abuse or neglect.

Notice

If the contents of this manual is subject to change, we will not notice additionally

Chapter1 Communication interface

IT6512/IT6513/IT6512A/IT6513A/IT6522A/IT6502D/IT6512D power supply have four standard communication interfaces: RS232,USB,GPIB,RS485. And IT6522A/IT6512D also have Ethernet interface. IT6532A/IT6533A/IT6523D power supply have four standard communication interfaces: RS232/USB/GPIB/Ethernet. You can choose any one according to his demands.

1.1 RS232 interface

Using a cable with two COM ports to connect power supply and PC. Then please press **Shift** + **OVP** (Menu) button to enter the menu to configure the communication parameters. You could do the secondary development with all SCPI commands.

Note : The setup about RS232 in the program should agree with the configuration in the system set. If you want to change the communication parameters, please press **Shift** + **OVP** (Menu) button to enter the system set.

RS-232 Data style

RS232 is a 10-bit data with start bit and stop bit. The start bit and stop bit can't be edited. While you could select the odd parity or even parity under the system set. Odd or EVEN options have been saved in the nonvolatile memory.

Baudrate

Edit baudrate: press **Shift** + **OVP** (Menu) to enter the menu setup, you could select the baudrate among the following options:
 4800 9600 19200 38400 57600 115200

RS-232 connection

Please use a straight-through RS232 cable with DB-9 interface and connect the RS232 serial port with the controller's serial port (for example, PC). Form 2-2 give a detailed description for each pin.

If your computer is using a RS232 interface with a DB-25 connector, you need a cable and a adaptor with a DB-25 connector at one end and DB-9 connector at the other end (not a null modem).

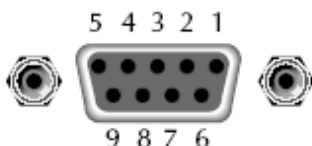

RS-232 pins description

Pin	description
1	connectionless
2	TXD, transmit data

3	RXD, receive data
4	connectionless
5	GND
6	connectionless
7	connectionless
8	connectionless
9	connectionless

RS-232 Troubleshooting :

If you meet some problems when communicating with PC by RS232 interface, please check the following items:

Please check the parameters setting

PC and power supply must have the same configuration in the following items: baudrate, parity bit, data bit and flow control. Please note that power supply has been configured with a start bit and stop bit (the two values are fixed).

Check the cable

Ensure you have used the correct communication cable. Please pay attention that some cable may not have a correct internal wiring even it is with an appropriate DB9 interface.

The RS232 communication cable should have been connected to a correct serial port of the PC (COM1, COM2, ext).

Communication Setup

Please ensure the PC and power supply have the same configuration in the following items.

baudrate : 9600 (4800, 9600, 19200, 38400, 57600, 115200). You could enter the system menu to set the baudrate.

Data bit : 8

Stop bit : 1

Parity bit : (none, even, odd)

EVEN 8 data bits have even parity

ODD 8 data bits have odd parity

NONE 8 data bits have no parity

Native machine address : (0 ~ 31 , factory default is 0)

Parity=None	Start Bit	8 Data Bits	Stop Bit
--------------------	------------------	--------------------	-----------------

1.2 USB interface

Use a cable with two USB ports to connect power supply and PC. You can program through USB interface to achieve all functions of power supply.

The functions of USB488 interface are as follows:

- ◆ Interface is 488.2 USB488 interface
- ◆ Receive the following request: REN_CONTROL, GO_TO_LOCAL, and LOCAL_LOCKOUT
- ◆ When the interface receives MsgID = TRIGGER USBTMC command, it will transmit the TRIGGER command to the function layer

The functions of power supply's USB488 are as follows:

- ◆ receive all SCPI commands
- ◆ device is SR1 enabled
- ◆ device is RL1 enabled
- ◆ device is DT1 enabled

1.3 GPIB Interface

Use a IEEE488 bus to connect GPIB interfaces of power supply and PC. Please ensure that the screws have been screwed down in order to have a full connection. Then press

Shift + **OVP** (Menu) to enter the system menu to set the address. The address range of

power supply is 0-31. After you set the address, please press **Enter** button to confirm. GPIB address is saved in nonvolatile memory.

1.4 RS485 Interface

Use a straight-through cable with two RS485 ports to connect power supply and PC.

Press **Shift** + **OVP** (Menu) button to enter the system set. Please set the following parameters: baudrate, data bit, stop bit, parity bit, native machine address. The setting way is the same with RS232 setting.

The definition for each pins of RS485:

1. Pin1 is B line of RS485 interface
2. Pin5 is A line of RS485 interface
3. The other pins are suspended



4.5 LAN Interface (Specialized Interface for model IT6522A/IT6512D)

Press **Shift** + **OVP** (Menu) button to enter the system set. Please select "ETHERNET" in the Communication from System and then configure Gateway, IP, Mask and SocketPort in the LAN option.

Connect the LAN interface of power supply to the computer with a reticle (crossed).

Chapter2 SCPI command table

2.1 IEEE488.2 Common commands

*CLS
 *ESE
 *ESE?
 *ESR?,
 *IDN?,
 *OPC,
 *OPC?,
 *RST,
 *PSC
 *PSC?
 *SRE,
 *SRE?,
 *STB?,
 *TRG,
 *SAV ,
 *RCL,

2.2 SCPI essential commands

STATus

:QUEStionable
 [:EVENT]?
 :CONDition?
 :ENABle <n>
 :ENABle?
 :PTRansition {<NR1>}
 :PTRansition?
 :NTRansition {<NR1>}
 :NPTRansition?

:OPERation
 :EVENT]?
 : CONDition?
 :ENABle <NR1>
 :ENABle?
 :PTRansition {<NR1>}
 :PTRansition?
 :NTRansition {<NR1>}
 :NPTRansition?

SYSTem

:ERRor?
 :VERSion?

```

:REMOte
:LOCAl
:RWLOCK
:POSetup {<RST | RCL0>}
:POSetup?
:CLEAr?
:BEEPer
:BEEPer?
:COMMunicate:GPIB:RDEVice:ADDReSS
:COMMunicate:GPIB:RDEVice:ADDReSS?
:INTerface

```

```

CONFIgure
:SAVe

```

```

Address

```

2.3 Display relative commands

```

DISPlay[:WINDow]
    [:STATe]
    [:STATe]?
    :TEXT[:DATA]
    :TEXT[:DATA]?
    :TEXT:CLEAr

```

2.4 Trigger commands

```

TRIGger
    [:IMMEDIATE]
    :SOURce {<source>}

:SOURce ?

```

2.5 Output commands

```

[SOURce:]
    OUTPut
        [:STATe] {<bool>}
        [:STATe]?

    RISe
        [:LEVel]
        [:LEVel]?

    FALL
        [:LEVel]
        [:LEVel]?

    CURRent

```



```

        [:LEVel]
            [:IMMediate]
                [:AMPLitude]
                [:AMPLitude]?
            :TRIGgered
                [:AMPLitude]
                [:AMPLitude]?
VOLTage
    [:LEVel]
        [:IMMediate]
            [:AMPLitude]
            [:AMPLitude] ?
        :TRIGgered
            [:AMPLitude]
            [:AMPLitude]?
    :PROTection
        [:LEVel]
        [:LEVel] ?
        :DELay
        :DELay ?
        :STATe
        :TRIGgered?
        :CLEar
    :LIMit
        [:LEVel]<voltage level>
        [:LEVel]?
    :RANGe< voltage level >
    :RANGe?
    
```

2.6 Compound control commands

```

[SOURce:] APPLy
    APPLy?
    
```

2.7 Measurement commands

```

MEASure[:SCALar]
    :VOLTage[:DC]?
    :CURRent[:DC]?
    :POWer[:DC]?
    
```

```

FETCh
    :VOLTage?
    
```

```

:CURRent?
:POWer?
SENSe
  :AVERage
    :COUNT
    :COUNT?

```

2.8 List operation commands (Specialized function for model IT6512/6513/IT6532A/IT6533A/IT6523D)

```

LIST
  :STATe
  :STATe?
  :RECall
  :RECall?
  :EDIT
  :EDIT?
  :POWer
  :POWer?
  :REPeat
  :REPeat?
  :LINK
    :SEQuence
    :SEQuence?
  :SEQuence
    :REPeat<NR1>< , NR1>
    :REPeat? <NR1>
  :SAVe

```

2.9 Sequence operation commands

```

SEQuence
  :EDIT
  :EDIT?
  :STEP
    :ACTive
    :ACTive?
  :VOLTage
  :VOLTage?
  :CURRent
  :CURRent?
  :WIDTh
  :WIDTh?
  :SLOPe

```

:SLOPe?

:SAVe

2.10 Calibration commands

CALibration

:SECure

[:STATe] {<0|1ON|OFF>,<quoted code>}

[:STATe]?

:VOLTagE

:LEVel {<P1 | P2> }

[:Data] {<numeric value>}

:CURRent

:LEVel {< P1 | P2> }

[:Data] {<numeric value>}

:STRing

:STRing?

:INITialize

:SAVe

Chapter3 SCPI status register

You can get the current status of the power supply by reading the operation status registers. The power supply records the different status of the instrument through the four status register group , the four status register group are: status byte register, standard event register, query status register and operation status register. Status byte register records the information of the other status register

BIT	Signal	Meaning
0	CAL	Operation status register The power supply is calculating the new calibration parameter.
3	WTG	The power supply is waiting for the trigger information.
4	CV	The power supply is in constant voltage status.
5	CC	The power supply is in constant current status.
0	OV	Query status register Over voltage
1	OC	Over current
3	OP	Over power
4	OT	Over temperature

Standard event register		
0	OPC	Operation completed. All the parallel operations are completed.
2	QYE	Query error. Output buffer data lost.
3	DDE	Instrument memory data loss or self test error
4	EXE	Execute error. Command parameter over flow or the operation condition is not consistent
5	CME	Command error. There is syntax or semantic error in the command received.
7	PON	Power on bit, this bit is set to 1 after power on
Status byte register		
2	EAV	Error buffer available
3	QUES	This bit is set to 1 when any one status of enabled query status register changes.
4	MAV	Output buffer available
5	ESB	Bit ESB is set to 1 when the status of a enabled standard event status register changes
6	RQS	
7	OPER	If the status of enabled operation register changes,then this bit is set to1.

The following chart is the Status register Structure of the power supply:

QUESTIONABLE STATUS register

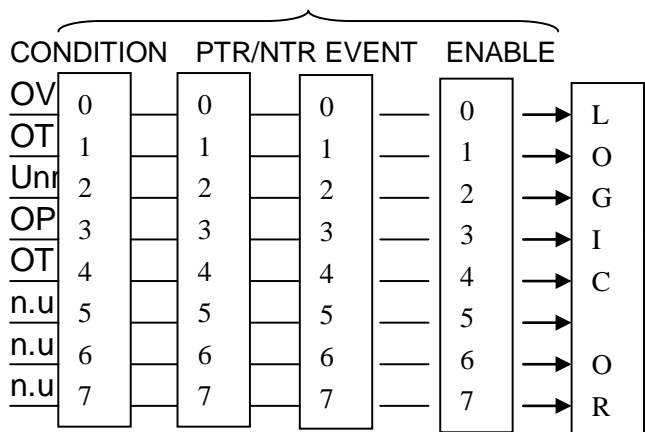

Error Queue

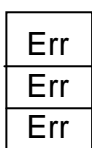

OPERATION STATUS REGISTER

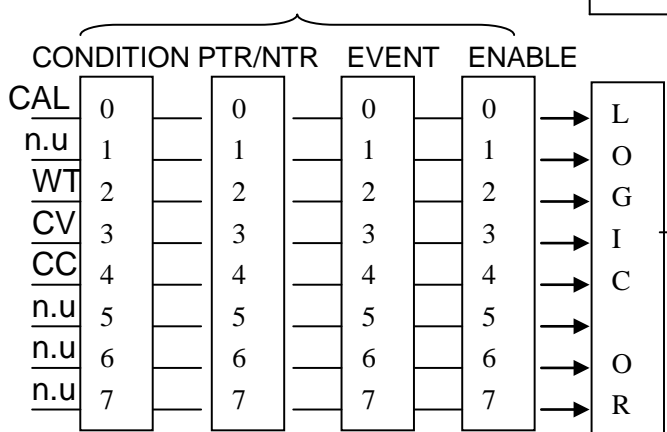

STATE BYTE REGISTER

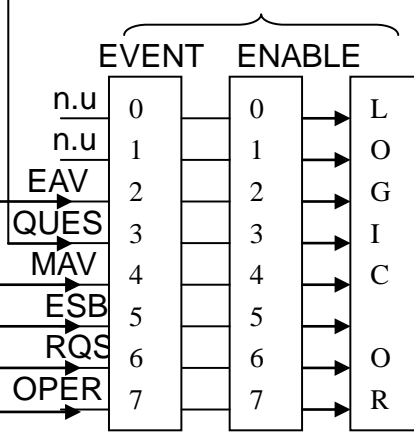

Output Buffer



STANDARD EVENT REGISTER

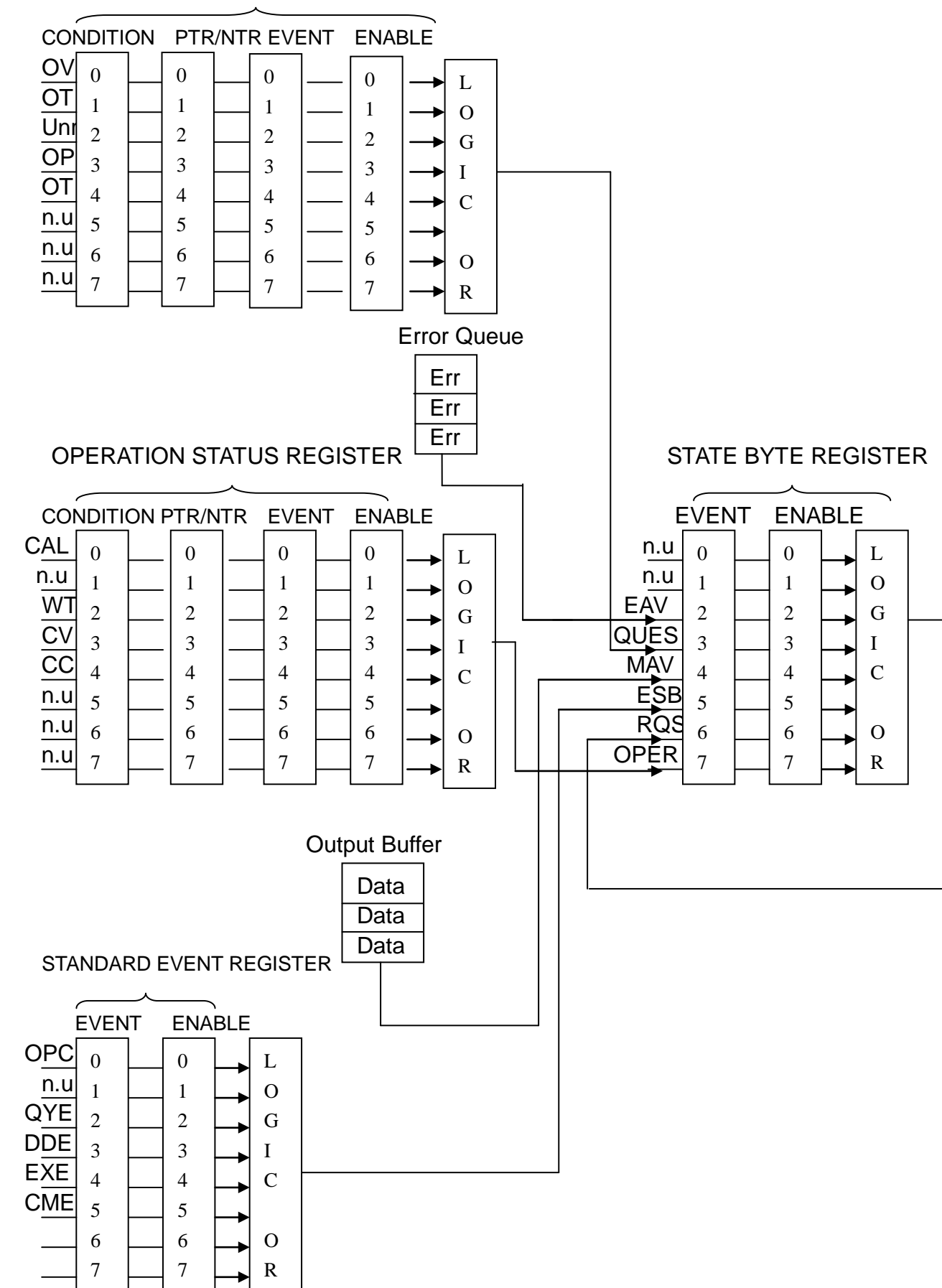
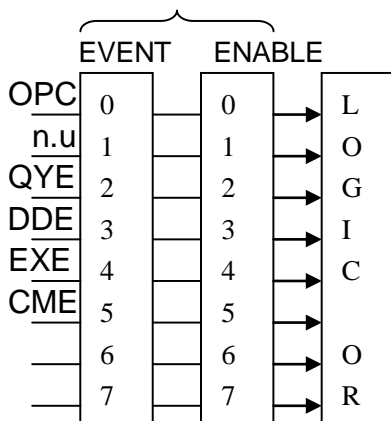

n.u
PON

Chapter4 SCPI Command description

4.1 IEEE488.2 common commands

*CLS

This command clears the following registers :

- Standard event register
- Query event register
- Operation event register
- Status byte register
- Error code

Command syntax : ***CLS**

Parameter: None

*ESE

This command can set the parameter of standard event enable register. Setting parameter can determine which bit of standard event register is 1 and the byte will enable ESB of status byte register is 1.

Command syntax : ***ESE <NR1>**

Parameter: 0~255

The value when power on : Refer to *PSC command

Example : *ESE 128

Query syntax : ***ESE ?**

Returned parameter : <NR1>

The bit definition of the standard event enabled register :

Bit Position	7	6	5	4	3	2	1	0
Bit name	PON	not used	CME	EXE	DDE	QYE	not used	OPC
Bit weight	128		32	16	8	4		1

PON Power-on

CME Command error

EXE Execution error

DDE Device-dependent error

QYE Query error

OPC Operation complete

***ESE?**

This command is used to read the standard event register

Query syntax : ***ESE ?**

Parameter: None

Returned parameter : <NR1>

***ESR?**

This command can read the value of standard event status register. After executing this command, standard event status register is reset. Bit definition of standard event status register is as the same as the standard event status enable register

Query syntax : ***ESR ?**

Parameter: None

Returned parameter : <NR1>

***IDN?**

This command can read information about power supply. The returns parameter contains 4 segments divided by comma.

Query syntax : ***IDN ?**

Parameter: None

Returned parameter : <AARD> segment description

ITECH Ltd	Manufacturer
6512	Product model
XXXXXX	Product serial number

VX . XX –VX . XX Software version

Example : ITECH , 6512 , 00000000000004 , V1.01-V1.00

***OPC**

When all commands before this command are executed, bit OPC in standard event register will be set to 1.

Command syntax : ***OPC**

Parameter: None

Query syntax : ***OPC ?**

Returned parameter : <NR1>

***RST**

This command reset the power supply to default settings.

**OUTP OFF CURR MIN
VOLT:PROT MAX VOLT MIN**

Command syntax : ***RST>**

Parameter: None

***SRE**

This command can set the parameter of state byte enable register. Setting parameter can determine which byte value of state byte register is 1 and the byte will set RQS of state byte register to 1. Bit definition of state byte enable register is as the same as the state byte register.

Command syntax : ***SRE <NR1>**

Parameter:0~255

Query syntax : ***SRE ?**

Returned parameter : <NR1>

***STB?**

This command can read the data from status byte register.

Query syntax : ***STB ?**

Parameter: None

Returned parameter : <NR1>

***TRG**

When power supply trigger source is a command from via BUS, this command will give a trigger signal. And its function is the same as "TRIGger" command.

Query syntax : ***TRG**

Parameter: None

Returned parameter : None

***SAV**

This command can save the current setups of power supply to specified memory. These setups contains current setups, voltage setups, max voltage set, min voltage set, OVP set, OVP timer, OPP set, voltage rise and fall time, analog interface and series and parallel set. The memory can divided into 10 groups, each contains 0~9 setups. So IT6512 can save 100

Setups in all.

Command syntax : ***SAV<NRf>**

Parameter: 0~9

***RCL**

This command can recall the setups you saved before from the specified memory.

Command syntax : ***RCL<NRf>**

Parameter: 0~9

4.2 SCPI essential commands

STATus:QUEStionable[:EVENT]?

This command can be used to read the value in query event register. After executing this command, the query event register will be cleared.

Query syntax : **STATus:QUEStionable[:EVENT]?**

Parameter: None

Returned parameter : <NR2>

Relative command : **STATus:QUEStionable:ENABLE**

The bit definition of query event enable register :

Bit position	15	14	13	12	11	10	9	8
Bit name	no use	no use	no use	no use	no use	no use	no use	no use
Bit weight								
Bit position	7	6	5	4	3	2	1	0
Bit name	no use	no use	no use	OT	OP	no use	OC	OV
Bit weight				16	8		2	1

STATus:QUEStionable:CONDition?

This command is used to read the value of query condition register. When a bit of quest condition changes, the bit value corresponding in quest event register is 1.

Query syntax : **STATus:QUEStionable: CONDition?**

Parameter:None

Returned parameter : <NR2>

STATus:QUEStionable:ENABLE

This command can set the parameter of quest event enable register. Setting parameter can

determine which bit value of quest event register is 1 and the bit will enable QUES

Command syntax : **STATus:QUEStionable:ENABle** <NR2>

Parameter:0~65535

Default set : Refer to *PSC command

Example : **STATus:QUEStionable:ENABle** 128

Query syntax : **STATus:QUEStionable:ENABle** ?

Returned parameter : <NR2>

STATus: QUEStionable:NTRansition

This command is used to edit the negative transition trigger register of operation event. The parameter determines which bits of operation event register is 1 will cause the OPER of status byte register to be 1.

Command syntax : **STATus: QUEStionable:NTRansition** <NR1>

Parameter:0~255

Example : **STATus: QUEStionable:NTRansition** 128

Query syntax : **STATus: QUEStionable:NTRansition** ?

STATus: QUEStionable:PTRansition

This command is used to edit the positive transition trigger register of operation event. The parameter determines which bits of operation event register is 1 will cause the OPER of status byte register to be 1.

Command syntax : **STATus: QUEStionable:PTRansition** <NR1>

Parameter:0~255

Example : **STATus: QUEStionable:PTRansition** 128

Query syntax : **STATus: QUEStionable:PTRansition** ?

STATus:OPERation[:EVENT]?

This command can read the parameter from operation event register. After executing this order, operation event register is reset.

Query syntax : **STATus: OPERation [:EVENT]?**

Parameter: None

Returned parameter : <NR1>

Relative command : **STATus: OPERation:ENABLE**

Bit definition of operation event register:

Bit position	7	6	5	4	3	2	1	0
Bit name	no use	no use	no use	CV	CC	WTG	no use	CAL
Bit weight				16	8	4		1

STATus:OPERation:CONDition?

This command can read the parameter from the operation condition register. When the parameter of operation condition register changes, the bit corresponding in operation event register is 1.

Query syntax : **STATus: OPERation: CONDition?**

Parameter:None

Returned parameter : <NR1>

STATus:OPERation:ENABLE

This command can set the parameter of operation event enable register. Setting parameter can determine which bit value of operation event register is 1 and the bit will cause OPER of status byte register to be 1.

Command syntax : **STATus: OPERation:ENABLE** <NR1>

Parameter:0~255

Example : **STATus: OPERation:ENABLE** 128

Query syntax : **STATus: OPERation:ENABLE ?**

Returned parameter : <NR1>

STATus:OPERation:NTRansition

This command is used to edit the negative transition trigger register of operation event. The parameter determines which bits in operation event register is 1 will cause the OPER bit of status byte register to be set to 1.

Command syntax : **STATus:OPERation:NTRansition** <NR1>

Parameter:0~255

Example : **STATus:OPERation:NTRansition** 128

Query syntax : **STATus:OPERation:NTRansition ?**

STATus:OPERation:PTRansition

This command edits the positive transition trigger register of operation event. The parameter determines which bits of operation event register is 1 will cause the OPER bit of status byte register to be set to 1.

Command syntax : **STATus:OPERation:PTRansition** <NR1>

Parameter:0~255

Example : **STATus:OPERation:PTRansition** 128

Query syntax : **STATus:OPERation:PTRansition** ?

SYSTem:ERRor?

This command is used to read the error code and the error information.
The following is the error code and the definition:

- (101) Too many numeric suffices
- (110) No input command
- (114) Invalid Numeric suffix
- (116) Invalid value
- (117) Invalid dimensions
- (120) Parameter overflowed
- (130) Wrong units for parameter
- (140) Wrong type of parameter
- (150) Wrong number of parameter
- (160) Unmatched quotation mark
- (165) Unmatched bracket
- (170) Invalid command
- (180) No entry in list
- (190) Too many dimensions

- (191) Too many char
- (-200) Execution error
- (-221) Settings conflict
- (-222) Data out of range
- (-223) Too much data
- (-224) Illegal parameter value
- (-225) Out of memory
- (-230) Data Corrupt or Stale
- (-270) Macro error
- (-310) System error
- (-350) Too many errors
- (-400) Query error
- (-410) Query INTERRUPTED
- (-420) Query UNTERMINATED
- (-430) Query DEADLOCKED"},
- (-440) Query UNTERMINATED
- (0) No error
- (1) Module Initialization Lost"
- (2) Mainframe Initialization Lost
- (3) Module Calibration Lost
- (4) Eeprom failure
- (5) RST checksum failed

(10) RAM selftest failed

(40) Flash write failed

(41) Flash erase failed"

(213) RS-232 buffer overrun

(216) RS-232 receiver framing

(217) RS-232 receiver parity

(218) RS-232 receiver overrun

(220) Front panel uart overrun

(221) Front panel uart framing

(222) Front panel uart parity"},

(223) Front panel buffer overrun

(224) Front panel timeout"},

(225) Front Crc Check error

(226) Front Cmd Error

(401) CAL switch prevents

(402) CAL password is incorrect

(403) CAL not enabled

(404) readback cal are incorrect

(405) programming cal are incorrect

(406) Incorrect sequence of cal

(600) FETCH of data was not acquired

(601) Measurement overrange

Command syntax : **SYST:ERR?**

Parameter:None

Returned parameter : <NR1> , <SRD>

SYSTem:VERSion?

This command is used to query the current SCPI version. The returned parameter is a string like "YYYY.V", in which the YYYY is the year of that version, V is the software version of that year.

Command syntax : **SYST:VERS?**

Parameter:None

Returned parameter : <NRf>

SYSTem:REMOte

This command is used to switch to the remote control mode(PC control).

Parameter:None

SYSTem:LOCal

This command is used to switch the instrument to local control mode(control from panel).

Command syntax : **SYST:LOCal**

Parameter:None

SYSTem:RWLock

This command is the same function as **SYSTem:REMOte** , but the difference is: this command can lock "LOCAL" button as well. When this command is executed, the "Local" button can't switch to local control mode.

Command syntax : **SYSTem:RWLock**

Parameter: None

SYSTem:POSetup

This command sets the parameters when the instrument power on.

Command syntax : **SYSTem:POSetup RST|SAV0**

Parameter:RST|SAV0

Returned parameter: None

Query syntax : **SYSTem:POSetup?**

SYSTem:POSetup?

Command syntax: **SYSTem:POSetup?**

Parameter: None

Returned parameter: RST|SAV0

SYSTem:CLEar

This command is used to clear the error information.

Command syntax: **SYSTem:CLEar**

Parameter: None

Returned parameter: None

SYSTem:BEEPer

This command is used to enable or disable the beeper.

Command syntax: **SYSTem:BEEPer**

Command syntax: **SYSTem:BEEPer**<bool>

Parameters:0|1|ON|OFF

Return parameters: None

inquiry command : **SYSTem:BEEPer?**

SYSTem:BEEPer?

Returned value 0 corresponds to the off state of beeper.

Returned value 1 corresponding to the on state of beeper.

Command syntax: **SYSTem:BEEPer?**

Parameters: None

Return parameters:0|1

SYSTem:COMMunicate:GPIB:RDEVice:ADDRess

This command is used to set the GPIB address.

Command syntax : **SYSTem:COMMunicate:GPIB:RDEVice:ADDRess** <NR1>

paramters : 0-31

inquiry syntax : **SYSTem:COMMunicate:GPIB:RDEVice:ADDRess?**

Return parameters : <NR1>

SYSTem:INTerface

This command is used to select the communication interfaces.

Command syntax : **SYSTem:INTerface** <GPIB|USB|RS232 |RS485>

ADDRESS

This command is used to set the slave machine's address when communicating through RS485 interface. If the value is 0, then all slave machines will deal with commands coming from main machine. If it is a nonzero value, then only the power supply with the same address with main machine's could deal with main machine's commands.

Command syntax : ADDRESS <NR1>

parameters : 0-31

4.3 Relative information about display

DISPlay[WINDow][:STATe]

This command is used to turn on or turn off the VFD display board. When display board is in off mode, then the output values will not be shown on the VFD screen.

Command syntax : DISPlay[:WINDow][:STATe] <bool>

Parameters : 0|1|ON|OFF

examples : DISPlay 1

inquiry syntax : **DISPlay[WINDow][:STATe]?**

Return parameters : 0|1

DISPlay[WINDow]:TEXT[:DATA]

This command is used to display one message on the VFD display board.

Command syntax : DISPlay[:WINDow]:TEXT[:DATA]<NR1><,>text with quotation>

parameters : The first parameter represents the display position(0~47). The second parameter is the characters to be displayed.

Inquiry syntax : **DISPlay[WINDow]:TEXT[:DATA]?**

Example: DISP:TEXT "1234"

DISPlay[WINDow]:TEXT:CLEAr

This command is used to clear all information on the front panel.

Command syntax : DISPlay[:WINDow]:TEXT:CLEAr

4.4 Trigger Commands

TRIGger[:IMMEdiate]

This command is used to create a trigger signal. It will give a trigger signal in BUS trigger

source mode. The function is the same as command *TRG.

Command syntax : TRIGger[:IMMEDIATE]

parameter : None

relative commands : *TRG TRIG:SOURce

TRIGger:SOURce

This command is used to select the trigger source. Power supply could receive trigger signal directly from front panel by pushing "Trigger" button or receive BUS trigger signal.

Command syntax : TRIG:SOURce <mode>

parameters : MANUAL |BUS

inquiry syntax : **TRIGger:SOURce?**

Return parameter : MANUAL |BUS

4.5 Output Command

[SOURce:]OUTPut[:STATe]

This command is used to control the output state of power supply.

Command syntax : [SOURce:]OUTPut [:STATe] <bool>

parameter : 0|1|ON|OFF

inquiry syntax : **[SOURce:]OUTPut[:STATe]?**

Return parameter : 0|1

[SOURce:]RISe[:LEVe]

This command is used to set the voltage rising time of power supply.

Command syntax : [SOURce:]RISe[:LEVe] <NRf>

unit : s

parameter : 0~65.535

inquiry syntax : [SOURce:]RISe[:LEVe]?

Return parameter : 0~65.535

[SOURce:]FALL[:LEVel]

This command is used to set the voltage falling time of power supply.

Command syntax : [SOURce:] FALL [:LEVel] <NRf>

unit : s

parameter : 0~65.535

inquiry syntax : [SOURce:] FALL [:LEVel]?

Return parameter : 0~65.535

[SOURce:]CURRent[:LEVel][:IMMediate][:AMPLitude]

This command is used to set the output current value.

Command syntax : [SOURce:]CURRent[:LEVel][:IMMediate][:AMPLitude] <NRf>

parameter : MIN TO MAX|MIN|MAX|DEF

unit : A |mA |uA

inquiry syntax : [SOURce:]CURRent[:LEVel][:IMMediate][:AMPLitude]?

parameter : None

return parameter : <NRf>

[SOURce:]CURRent[:LEVel]:TRIGgered[:AMPLitude]{<current level> | MINimum | MAXimum }

This command is used to set a current value to be triggered. Different from general current value, this value will be effective until it receives a trigger signal. Sending CURRent command will not impact this command's current setting value. Sending inquiry command will return the original setting value.

Command syntax : [SOURce:]CURRent[:LEVel]:TRIGgered[:AMPLitude] <NRf>

parameter : MIN TO MAX|MIN|MAX|DEF

unit : A

inquiry syntax : [SOURce:]CURRent[:LEVel]:TRIGgered[:AMPLitude]?

Return parameter : <NRf>

[SOURce:]VOLTage[:LEVel][:IMMEDIATE][:AMPLitude]

This command is used to set the output voltage value.

Command syntax : [SOURce:]VOLTage[:LEVel][:IMMEDIATE][:AMPLitude] <NRf>

parameters : MIN TO MAX|MIN|MAX|DEF

unit : V| mV| uV

inquiry syntax : [SOURce:]VOLTage[:LEVel][:IMMEDIATE][:AMPLitude] ?

parameter : None

return parameter : <NRf>

[SOURce:]VOLTage[:LEVel]:TRIGgered[:AMPLitude]{<voltage level> |MINimum | MAXimum}

This command is used to set a voltage value to be triggered. Different from general voltage value, this value will be effective until it receives a trigger signal. Sending VOLTage command will not impact this command's voltage setting value. Sending inquiry command will return the original setting value.

Command syntax : [SOURce:]VOLTage[:LEVel]:TRIGgered[:AMPLitude] <NRf>

parameters : MIN TO MAX|MIN|MAX|DEF

unit : V| mV| uV

inquiry syntax : [SOURce:]VOLTage[:LEVel]:TRIGgered[:AMPLitude]?

Return parameter : <NRf>

[SOURce:]VOLTage:PROTection[:LEVel]

This command is used to set the software-voltage protection value.

Command syntax : [SOURce:] VOLTage:PROTection[:LEVel] <NRf>

parameter : MIN TO MAX|MIN|MAX|DEF

parameters : V |mV| uV

inquiry syntax : [SOURce:] VOLTage:PROTection[:LEVel] ?

Parameters:None

Return parameter:<NRf>

[SOURce:]VOLTage:PROTection:DELAy

This command is used to set the software-voltage protection delay time.

Command syntax : [SOURce:]VOLTage:PROTection:DELAy<NRf>

parameter : 0.001~0.6

unit : s

inquiry syntax : [SOURce:]VOLTage:PROTection:DELAy ?

Parameter : 0.001~0.6

Return parameter : <NRf>

[SOURce:]VOLTage:PROTection:STATe

This command is used to set the software-voltage protection state.

Command syntax : [SOURce:]VOLTage:PROTection:STATe<bool>

parameter : 0|1|ON|OFF

inquiry syntax : [SOURce:]VOLTage:PROTection:STATe ?

parameter : None

return parameter : 0|1

[SOURce:]VOLTage:PROTection:TRIGgered?

This command is used to inquire the executing state of over voltage protection.If return "1",this indicates the OVP circuit has been triggered and the OVP state does not be cleared.If return "0",which means OVP circuit is not be triggered.

Command syntax : [SOURce:]VOLTage:PROTection:TRIGgered?

Return value : 0|1

[SOURce:]VOLTage:PROTection:CLEAr

This command is used to clear the OVP state.Before sending this command,please increase the upper limitation of OVP or you can also reduce the output voltage.

Note:Please remove the external power supply which caused this protection and then send this command.

Command syntax : [SOURce:]VOLTage:PROTection:CLEar

[SOURce:]VOLTage:LIMit[:LEVel]<voltage>

This command is used to set the lower limitation of output voltage

Command syntax : [SOURce:]VOLTage:LIMit[:LEVel] <NRf>

parameter : MIN TO MAX|MIN|MAX|DEF

unit : V| mV| uV

inquiry syntax : **[SOURce:]VOLTage:LIMit[:LEVel]?**

Return parameter : <NRf>

[SOURce:]VOLTage:RANGe<voltage>

This command is used to set the upper limitation of output voltage

Command syntax : [SOURce:]VOLTage:RANGe <NRf>

parameter : MIN TO MAX|MIN|MAX|DEF

unit : V |mV |uV

inquiry syntax : [SOURce:]VOLTage:RANGe?

Return parameter : <NRf>

4.6 Composite Control Command

[SOURce:]APPLy {<voltage>|MIN|MAX} [, {<current> |MIN|MAX}]

This command has combined two kinds of commands----VOLTage and CURRent.As long as the setting value is within the range of max current and max voltage,then the output voltage and current will execute according to the present setting value.APPLy command will only be effective when the setting values are within the range of upper limitation.If not,an execution error will occur.MIN and MAX can also be used as special parameters.Min will enable the output voltage and current to be 0.Max will enable the output voltage and current to be the upper limitation value.

Command syntax : [SOURce:]APPLy <NRf>,<NRf>

parameter : MIN~MAX

unit : V, A

inquiry syntax : [SOURce:]**APPLy?**

Return parameter : <NRf>,<NRf>

4.7 Input Measuring Commands

MEASure[:SCALar]:VOLTage[:DC]?

This command is used to enquire the actual output voltage.

Command syntax : **MEASure[:SCALar]:VOLTage[:DC]?**

Parameter : None

Return parameter : <NRf>

Return parameter's unit : V

example : **MEAS:VOLT ?**

FETCh:VOLTage?

This command is used to read the voltage to be handled in the sample cache. After sending the command and let the instrument dialogue, the readings will be sent to the computer. This command does not affect the instrument settings. This command does not trigger a measurement operation, requires only the latest available reading. Before reading the new, the command returns are old readings.

Command syntax : **FETCh:VOLTage?**

Return parameter : <NRf>

Return parameter's unit : V

MEASure[:SCALar]:CURRent[:DC]?

This command is used to read the actual current.

Command syntax : **MEASure[:SCALar]:CURRent[:DC]?**

parameter : None

return parameter : <NRf>

return parameter's unit : A

example : **MEAS:CURR ?**

FETCh:CURRent?

This command is used to read the current which is to be handled in the sample cache. After sending the command and let the instrument dialogue, the readings will be sent to the computer. This command does not affect the instrument settings. This command does not trigger a measurement operation, requires only the latest available reading. Before reading the new, the command returns are old readings.

Command syntax : FETCh:CURRent?

Return parameter : <NRf>

MEASure[:SCALar]:POWER[:DC]?

This command is used to enquire the actual output power.

Command syntax : **MEASure[:SCALar]:POWER[:DC]?**

Parameter : None

Return parameter : <NRf>

Return parameter's unit : W

example : **MEAS:POWER?**

FETCh:POWER?

This command is used to read the power in the sample cache. After sending the command and let the instrument dialogue, the readings will be sent to the computer. This command does not affect the instrument settings. This command does not trigger a measurement operation, requires only the latest available reading. Before reading the new, the command returns are old readings.

Command syntax : FETCh:POWER?

Return parameter : <NRf>

SENSe:AVERage:COUNT

This command is used to set the number of measuring filtering.

Command syntax : SENSe:AVERage:COUNT<NR1>

parameter : 0-15

inquiry syntax : SENSe:AVERage:COUNT?

Return parameter : 0-15

4.8 List Operation Commands(Specialized function for model IT6512/6513/IT6532A/IT6533A/IT6523D)

LIST:STATe

This command is used to set the state of list mode.

Command syntax : LIST:STATe<0|1|ON|OFF>

Inquiry syntax : LIST:STATe?

Return parameter : 0|1

LIST:RECall

This command is used to recall a list file.

Command syntax : LIST:RECall<NR1>

parameter : 1~10

inquiry syntax : LIST:RECall?

Return parameter : 1~10

LIST:EDIT

This command is used to select list file which has been edited.

Command syntax : LIST:EDIT<NR1>

parameter : 1~10

inquiry syntax : LIST:EDIT?

Return parameter : 1~10

LIST:POWER

This command is used to edit the power of list file.

Comman syntax : LIST:POWER<NRf>

parameter : MIN~MAX

inquiry syntax : LIST:POWER?

Return parameter : MIN~MAX

LIST:REPeat

This command is used to edit the running times of list file.

Command syntax : LIST:REPeat <NR2>

parameter : 1~65535

inquiry syntax : LIST:REPeat?

Return parameter : 1~65535

LIST:LINK:SEQuence

This command is used to edit the list sequence to be linked.

Command syntax : LIST:LINK:SEQuence <NR2>

parameter : 0~1023

inquiry syntax : LIST:LINK:SEQuence?

Return parameter : 0~1023

LIST:SEQuence:REPeat<NR1>< , NR1>

This command is used to edit the running count of sequence which is linked to the List file.

Command syntax : LIST:SEQuence:REPeat<NR1>< , NR1>

Parameter:Parameter1 represents the sequence number,parameter2 corresponds to the running count of sequence (1~65535) .

Inquiry syntax : LIST:SEQuence:REPeat? <NR2>

Return parameter : 0~65535

LIST:SAVe

This command is used to save the list file in a nonvolatile memory.

Command syntax : LIST:SAVe

parameter : None

4.9 Sequence Operation Command

SEquence:EDIT

This command is used to select the list sequence to be edited.

Command syntax : SEquence:EDIT<NR1>

parameter : 1~10

inquiry syntax : SEquence:EDIT?

Return parameter : 1~10

SEquence:STEP:ACTive

This command is used to select the steps to be activated of sequence.

Command syntax : SEquence:STEP:ACTive<NR2>

parameter : 0~1023

inquiry syntax : SEquence:STEP:ACTive?

Return parameter : 0~1023

SEquence:VOLTage

This command is used to edit the voltage of specified step of the sequence.

Command syntax : SEquence:VOLTage<NR1><,>NRf>

unit : V

parameter:Parameter1 represents the number of step to be edited.Parameter2 is the voltage (MIN~MAX).

Inquiry syntax : SEquence:VOLTage? <NR1>

Return parameter : MIN~MAX

SEquence:CURRent

This command is used to edit the current of specified step of a sequence file.

Command syntax : SEquence:CURRent<NR1><,>NRf>

parameter : Parameter1 represents the number of step to be edited.Parameter2 is the current (MIN~MAX).

inquiry syntax : SEQuence:CURRent? <NR1>

return parameter : MIN~MAX

SEQuence:WIDTh

This command is used to edit the width of specified step of the sequence file .

Command syntax : SEQuence:WIDTh <NR1><,NRf>

parameter : Parameter1 represents the number of steps to be edited.Parameter2 is the time width (0.001~65.535).

unit : s

inquiry syntax : SEQuence: WIDTh? <NR1>

return parameter : 0.001~65.535

SEQuence:SLOPe

This command is used to edit the slope of a specified step of the sequence file, this command is only effective for IT6512/IT6513.

Command syntax : SEQuence:SLOPe <NR1><,NRf>

parameter : Parameter1 represents the number of steps to be edited.Parameter2 is the slope(0.001~65.535).

unit : s

inquiry syntax : SEQuence:SLOPe? <NR1>

return parameter : 0.001~65.535

SEQuence:SAVe

This command is used to save the sequence file.

Command syntax : SEQuence:SAVe

Parameter:None

4.10 Calibration Commands

CALibration:SECure

This command is used to enable or disable the protection mode.

Command syntax : **CALibration:SECure** {<0|1>,[<password>]}

parameter : 0|1|ON|OFF, '6512'

example : CAL:SEC 0, '6512'; CAL:SEC 1

inquiry syntax : **CALibration:SECure ?**

parameter : None

CALibration:VOLTage:LEVel

This command is used to define the voltage calibration point. P1 and P2 calibration points should be calibrated according to priority.

Command syntax : **CALibration:VOLTage:LEVel <point>**

parameter : P1|P2

CALibration:VOLTage [:DATA] {<numeric value>}

This command is used to read the actual voltage of the present calibration point.

Command syntax : **CALibration:VOLTage [:DATA] <NRf>**

parameter : <NRf>

example : CAL:VOLT 80.0002V

CALibration:CURREnt:LEVel

This command is used to define the current calibration points. P1 and P2 calibration points should be calibrated according to priority.

Command syntax : **CALibration:CURREnt:LEVel <point>**

parameter : P1|P2

CALibration:CURREnt [:DATA] {<numeric value>}

This command is used to read the actual current of the present calibration point.

Command syntax : **CALibration:CURREnt [:DATA] <NRf>**

parameter : <NRf>

example : CAL:CURR 3.002A

CALibration:SAVE

This command is used to save the calibration parameters in a nonvolatile memory.

Command syntax : **CALibration:SAVe**

parameter : None

CALibration:STRing

This is used to set the calibration information

Command syntax : CALibration:STRing <parameter>

Parameter : The max length is a char with 20 letters,i.e the relative information during the calibration process,such as calibration date.

example : CAL DATE: 2011/01/01

CALibration:STRing?

This is used to view the information of the time.

Inquiry syntax : CALibration:STRing?

Return parameter : calibration information saved in the power supply

CALibration: INITialize

This command is used to initialize the calibration parameters.

Command syntax : CALibration: INITialize

parameter : None