

Agilent PNA Millimeter-Wave Network Analyzers 10 MHz to 110 GHz, and extensions to 500 GHz

Technical Overview



High Performance Bench-Top Network Analyzers

- Maximize your frequency coverage with a single sweep from 10 MHz to 110 GHz, and realize measurements to 500 GHz with frequency extensions
- Minimize space and maintenance costs with compact test heads and two built-in synthesizers
- Optimize your test setup with 29 IFBW settings, 32 channels, 64 traces, and 20,001 points
- Capitalize on high performance with exceptionally accurate measurements inherent to the PNA Series of network analyzers



*Built on a solid foundation, the Agilent millimeter-wave solutions bring PNA Series **performance, flexibility, ease-of-use, and connectivity** to your design and test challenges in millimeter-wave applications.*

The Agilent N5250A 110 GHz system is the only bench-top, broadband system with integrated tri-axial bias tees that provides accurate control of device bias through its force/sense ability. This system is ideal for device characterization, modeling and parameter extraction in coaxial or on-wafer because accurate biasing leads to precise characterization, and broad frequency coverage down to 10 MHz offers superb time domain resolution.



N5250A Key Features and Benefits

- 10 MHz to 110 GHz frequency range in a single sweep.
- Deliver accurate biasing through tri-axial bias tees near test ports.
- 20,001 points allow you to calibrate once over a wide frequency range and then focus in on frequencies of interest.
- Two new calibration capabilities, data-based calibration standards and expanded calibration algorithm, offer enhanced accuracy and design confidence.
- Code compatibility available to help Agilent 8510 users to migrate to the innovative and flexible PNA series platform.

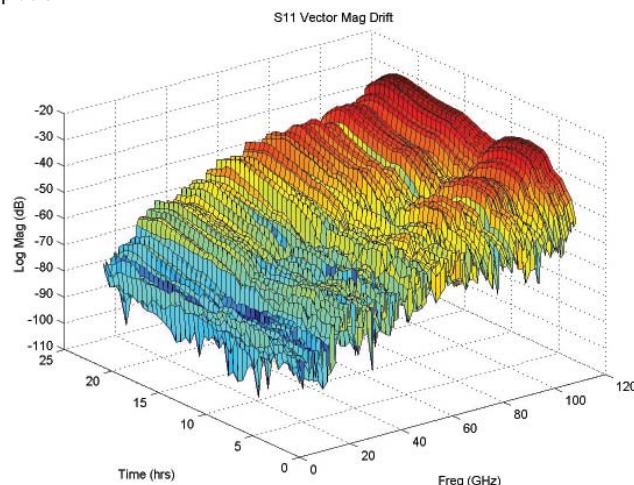

N5250A PNA Millimeter-Wave Network Analyzer

Performance

The N5250A offers unsurpassed performance for broadband, mm-wave measurements. Figure 1 demonstrates the superb dynamic range of the N5250A system compared to Agilent's previous 8510XF system when measuring a connectorized bandpass filter at 94 GHz.

The N5250A also offers superb speed with measurements up to 42 times faster than the 8510XF. All of this performance comes in a compact package that requires no external synthesizers. The port 1 millimeter-wave test head has a 25 dB attenuator to control power using a continuously adjustable micrometer.

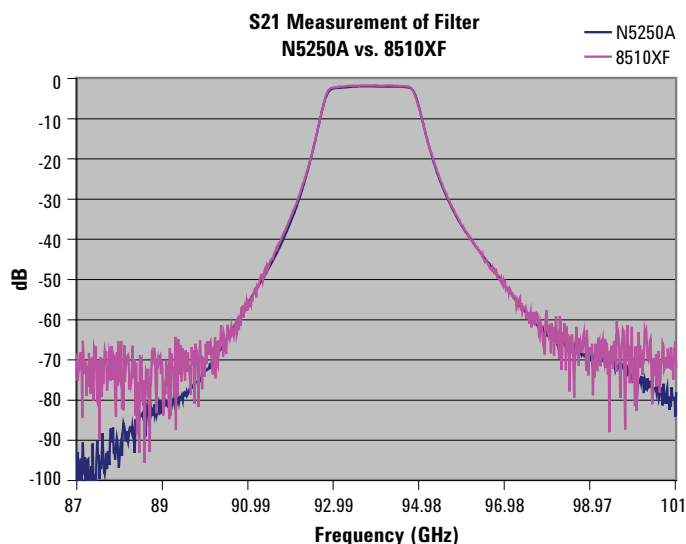

Figure 1. S₂₁ filter measurement comparisons with Agilent's N5250A and 8510XF systems.

The N5250A offers excellent performance for on-wafer measurements as well. Options 017 and 018 add 67 GHz bias-tees to the combiner assembly, between the input to the combiner and the 67 GHz coupler. The bias-tees have tri-axial connectors for force, sense, and ground. Positioning the bias-tees close to the DUT greatly improves stability for on-wafer and in-fixture devices.



Figure 2. N5250A 110 GHz millimeter-wave system with Cascade Microtech's probe station.

Figure 3 shows an S_{21} measurement of a 40 ps transmission line made on a Cascade Microtech¹ Summit probe station with Infinity probes. The N5250A is fully compatible with the Wavevue Measurement Studio Software from Cascade.

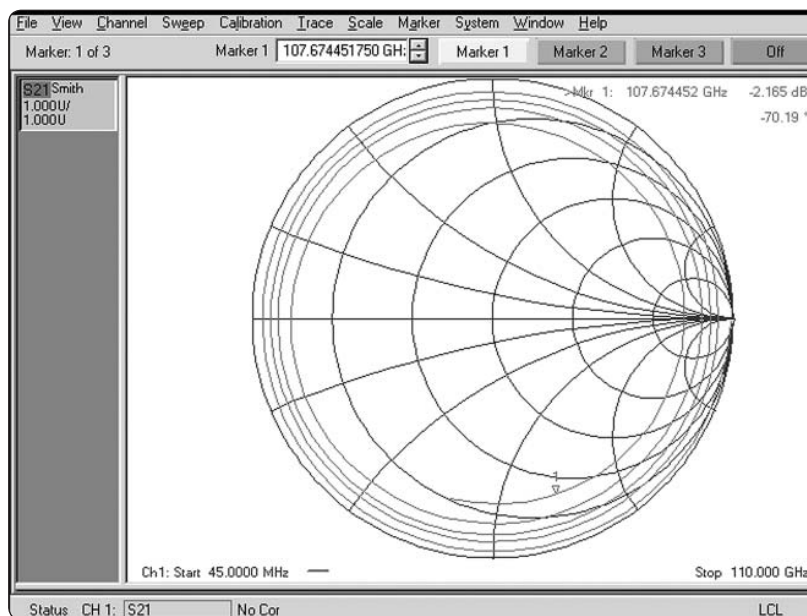

Figure 3. S_{21} measurement of a 40 ps transmission line made on a Cascade Microtech Summit probe station with Infinity probes.

Flexibility

The N5250A builds on the flexibility and performance of Agilent's PNA series of network analyzers. Purchase the full N5250A system, and have the flexibility of both a 10 MHz to 67 GHz PNA and mm-wave heads covering 67 GHz to 110 GHz, which combine to create a broadband, high performance 110 GHz system.

Alternatively, purchase an E8361A PNA with Option H11 (covering 10 MHz to 67 GHz) now, and you can easily upgrade in the future to the 110 GHz system by simply adding the N5260A mm-wave controller with test heads.

Ease-of-use

The N5250A uses the standard PNA firmware, allowing you to: leverage software between PNA Series network analyzers, regardless of the frequency range of your measurement; manually control the instrument, using either the front panel or a mouse to access the simple pull-down menus; and utilize the Cal Wizard, which will guide you step-by-step through the most complicated of calibrations.

Also, an extensive, context-sensitive Help system thoroughly explains all of the PNA's features. In any dialogue box, simply click on the "Help" button to see a detailed explanation of the feature you are using. Programming examples in both SCPI and COM are also included.

1. Cascade Microtech is an Agilent channel partner. www.cascademicrotech.com

Connectivity

Windows® built-in operating system and familiar user interface provides both ease-of-use and connectivity.

- Capture images quickly, easily and in .jpg, .bmp, and .png formats for easy data analysis, archiving, and printing.
- Control the analyzer using SCPI commands or gain the speed and connectivity advantage of COM/DCOM.
- Develop code in programming environments such as Visual Basic®, Visual Basic.NET, Visual C++, Visual C++.NET, Agilent-VEE, or LabView.
- Execute code directly from the analyzer or remotely with an external PC through LAN or GPIB, or multiple USB ports.
- Use multiple USB ports to control a variety of peripherals.

The N5250A PNA and the entire series of microwave PNA instruments are based on the Windows® XP operating system, which makes operation and programming simple, and provides a powerful environment in which easy-to-use measurement functions and PC capabilities are seamlessly linked. In addition, the new millimeter-wave PNA has linkages to Agilent's Advanced Design System (ADS) and IC-CAP modeling software.

For parameter extraction and device modeling, the N5250A is compatible and fully supported by the Agilent IC-CAP modeling software, the platform of choice for high frequency device modeling. IC-CAP is an open platform that offers flexibility for RF engineers to modify and customize their own models and thus, enhancing model accuracy.

Typical Performance¹

Test port power (dBm)	1.0 mm test port (standard configuration ² or Option 017 ³)	1.85 mm PNA port
10 to 45 MHz	-8	-7
45 to 500 MHz	-3	-1
500 MHz to 2 GHz	0	+2
2 to 10 GHz	-2	+2
10 to 24 GHz	-5	0
24 to 30 GHz	-7	0
30 to 40 GHz	-10	-1
40 to 45 GHz	-15	-5
45 to 50 GHz	-12	-1
50 to 60 GHz	-17	-4
60 to 67 GHz	-19	-8
67 to 70 GHz	-9	n/a
70 to 75 GHz	-7	n/a
75 to 80 GHz	-6	n/a
80 to 100 GHz	-5	n/a
100 to 110 GHz	-8	n/a

Noise floor ⁴ (dBm)	1.0 mm test port	1.85 mm PNA port
10 to 45 MHz	-71	-72
45 to 500 MHz	-97	-98
500 MHz to 2 GHz	-120	-121
2 to 10 GHz	-118	-121
10 to 24 GHz	-116	-121
24 to 30 GHz	-107	-112
30 to 40 GHz	-102	-108
40 to 45 GHz	-99	-106
45 to 50 GHz	-97	-104
50 to 60 GHz	-95	-104
60 to 67 GHz	-92	-103
67 to 70 GHz	-92	n/a
70 to 75 GHz	-96	n/a
75 to 80 GHz	-95	n/a
80 to 100 GHz	-94	n/a
100 to 110 GHz	-95	n/a

System dynamic range ⁴ (dB)	1.0 mm test port	1.85 mm PNA port
10 to 45 MHz	63	65
45 to 500 MHz	94	97
500 MHz to 2 GHz	120	123
2 to 10 GHz	116	123
10 to 24 GHz	111	121
24 to 30 GHz	100	112
30 to 40 GHz	92	107
40 to 45 GHz	84	101
45 to 50 GHz	85	103
50 to 60 GHz	78	100
60 to 67 GHz	75	95
67 to 70 GHz	83	n/a
70 to 75 GHz	89	n/a
75 to 80 GHz	89	n/a
80 to 100 GHz	89	n/a
100 to 110 GHz	87	n/a

Test port damage level (dBm)	1.0 mm test port	1.85 mm PNA port
10 MHz to 110 GHz	+27	+27

1. Typical performance is expected performance of an average unit which does not include guardbands. It is not covered by the product warranty.

2. Assumes a 30-inch cable from PNA 1.85 mm Test Port Out is used to provide the 10 MHz to 67 GHz source signal. The standard configuration does not have a bias tee in the 1.0 mm head.

3. Assumes a 30-inch cable from PNA Source Out bulkhead connector is used to provide the 10 MHz to 67 GHz source signal. Option 017 includes a bias tee in the 1.0 mm head.

4. Measured at test port in a 10 Hz bandwidth.

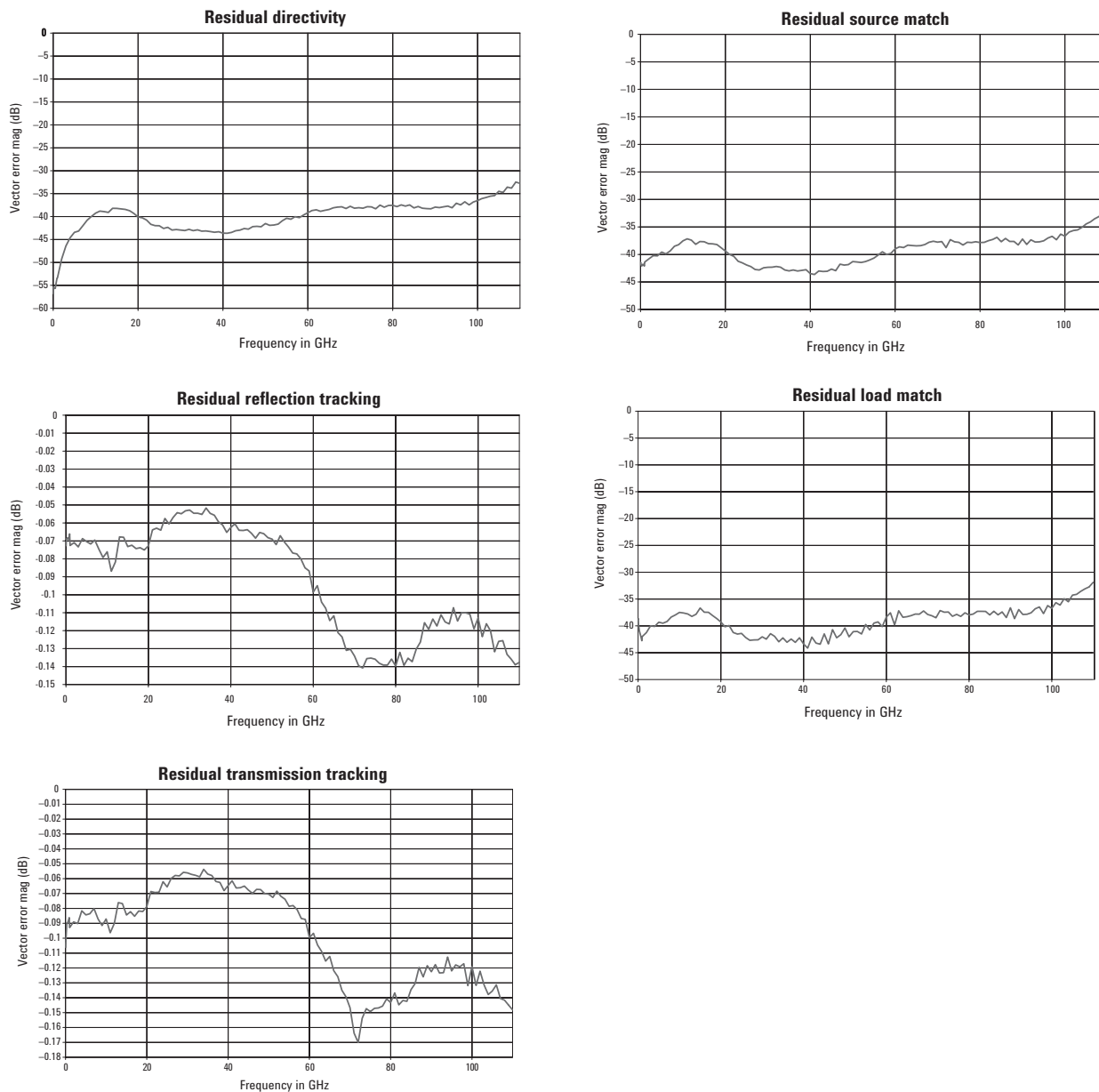

Figure 4. Plots showing residual calibration errors based on a coverage factor of 2 (2 sigma).

Measurement cycle time¹ (ms) Forward sweep, uncorrected

	Number of points					
	51	101	201	401	801	1601
10 MHz to 110 GHz 10 kHz IFBW	300	400	500	600	700	1000
58 to 62 GHz 10 kHz IFBW	111					
75 to 79 GHz 10 kHz IFBW	93					

Cycle time vs. IF bandwidth Forward sweep, uncorrected, 201 points

IF bandwidth (Hz)	45 MHz to 100 GHz cycle time (ms)	75 to 79 GHz cycle time (ms)
10000	500	93
1000	800	267
100	3500	2000
10	20900	18200

1. "Cycle time" includes sweep time, retrace time, and band-crossing time. For a full 2-port corrected measurement with forward and reverse sweeps, the cycle times above should be approximately doubled.

N5250A system block diagram

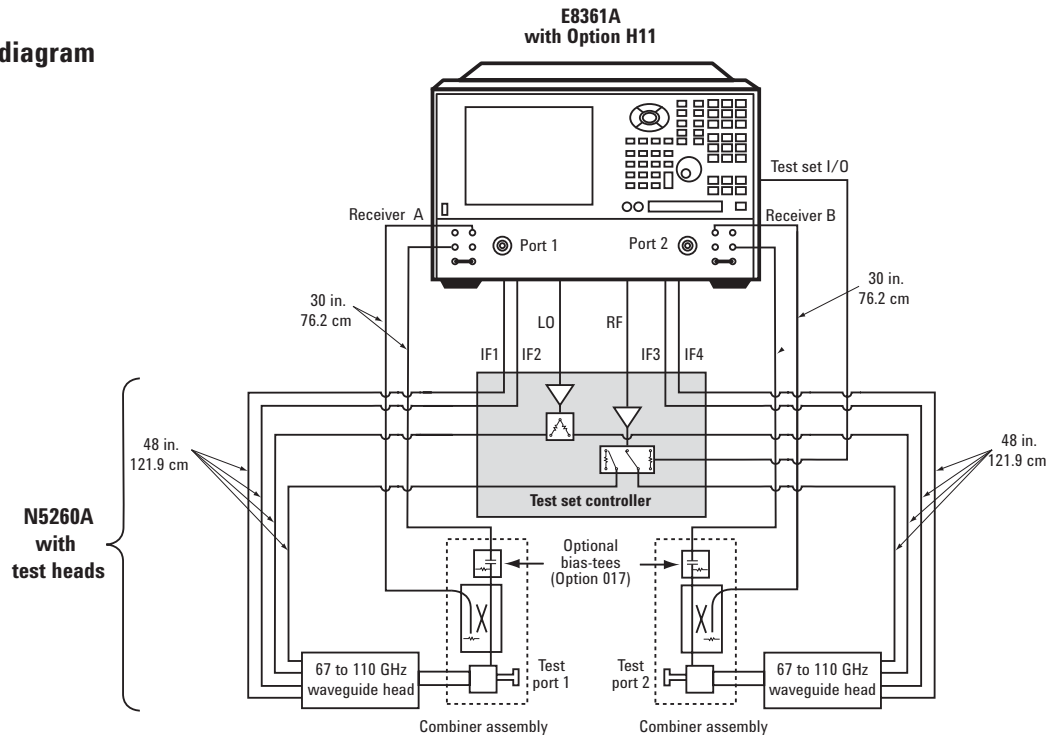

Figure 5. With Option 017, the signal is routed out of PNA from the front panel jumpers rather than the ports. Without Option 017, the signal is routed from the front panel ports to the combiner assembly, allowing access to the PNA's internal bias-tees.

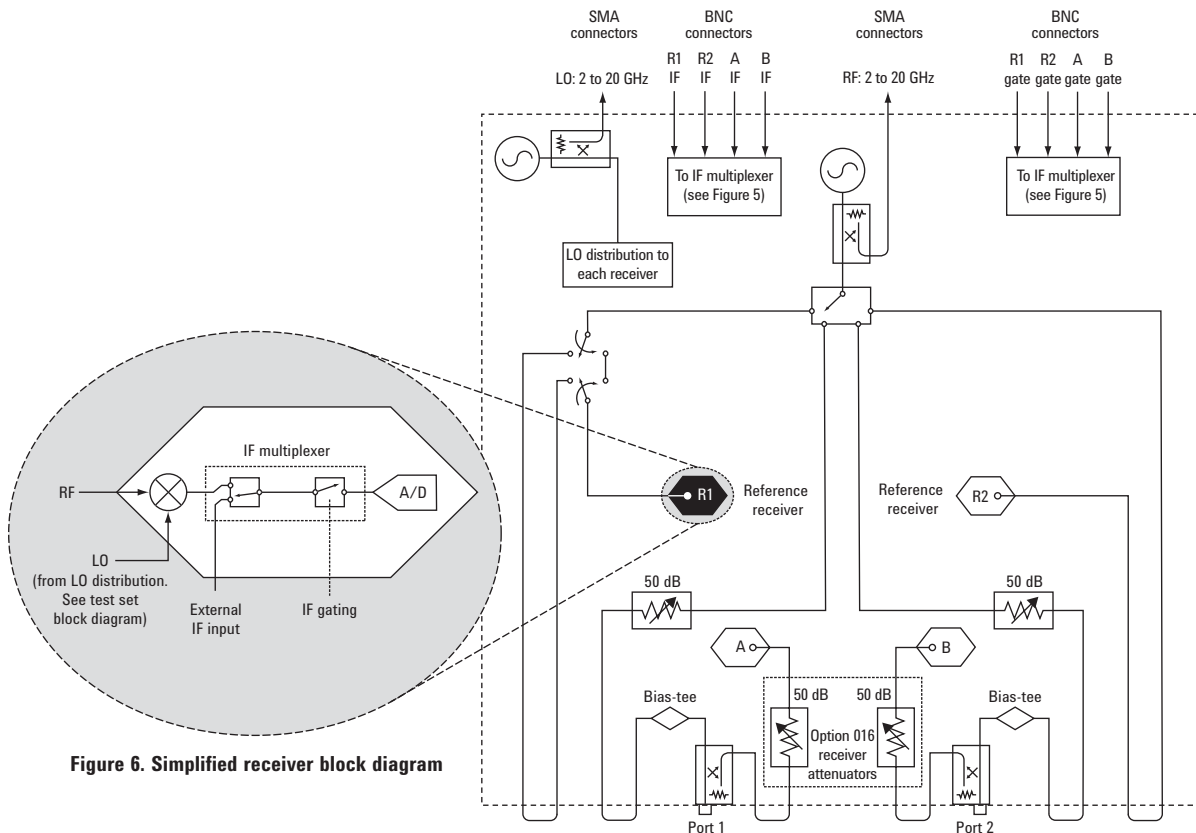

Figure 6. Simplified receiver block diagram

Figure 7. PNA test set block diagram

The Agilent banded millimeter-wave system provides measurement capabilities up to 500 GHz! Systems are extremely easy to configure and can be adapted to different needs as your measurement requirements change.



Banded Millimeter-Wave Key Features and Benefits

- Wide selection of waveguide modules available to cover from 50 GHz to 500 GHz!
 - N5260AW15, 50 to 75 GHz
 - N5260AW12, 60 to 90 GHz
 - N5260AW10, 75 to 110 GHz
 - N5260AW08, 90 to 140 GHz
 - N5260AW06, 110 to 170 GHz
 - N5260AW05, 140 to 220 GHz
 - N5260AW03, 220 to 325 GHz
 - N5260AS02, 325 to 500 GHz
 - Flexible configuration, evolve as your needs grow
 - Up to 20 dB improvement of dynamic range can be achieved by adding external synthesizers²
1. VNA2 waveguide modules from OML, Inc. are compatible with PNA banded millimeter-wave systems. VNA1 waveguide module from OML, Inc. may be used with 8510 systems. These VNA1 waveguide modules can be upgraded to VNA2 modules. Please contact OML, Inc. for details of upgrade, or visit OML, Inc. at www.omlinc.com
 2. For systems based on the PNA (not PNA-X), adding external synthesizers can improve dynamic range significantly at or above 220 GHz, while slight improvement can be seen between 110 GHz and 220 GHz.
 3. External synthesizers used are the Agilent PSG Series, E8257D with Options 520 (20 GHz) and UNX (Ultra-low Phase Noise). Two external synthesizers are required; one for the RF signal and the other for the LO signal.
 4. This plot is intended for use as a reference, and not as specifications. PNA system configuration included the E8362B 20 GHz MW PNA with Options H11, UNL, 014, 080 & 081, the N5260A mm-wave test set controller with one WR-05 Transmission/Reflection (T/R) test head module and one WR-05 Transmission-only (T) test head module. (One T/R module and one T module allow for S11 and S21 measurements. Two T/R modules allow for S11, S21, S12 and S22 measurements.) External synthesizers were added for dynamic range comparison. Measurement setup: 201 points, 10 Hz IF BW, and no average.

Performance

Banded millimeter-wave systems configured with the PNA-X offer exceptional dynamic range all the way to 500 GHz without additional external synthesizers. See Figure 9 for comparisons of waveguide band WR-03. Plus, pulsed millimeter-wave measurements can easily be achieved by simply adding built-in pulse generators and modulators, with no extra external equipment required.

With the PNA banded millimeter-wave system configured to make measurements from 140 GHz to 220 GHz (WR-05 waveguide band), dynamic range better than 60 dB across the entire band is achievable without any external synthesizers. As shown in Figure 8, adding two external synthesizers³ can improve dynamic range up to 10 dB across the frequency range.

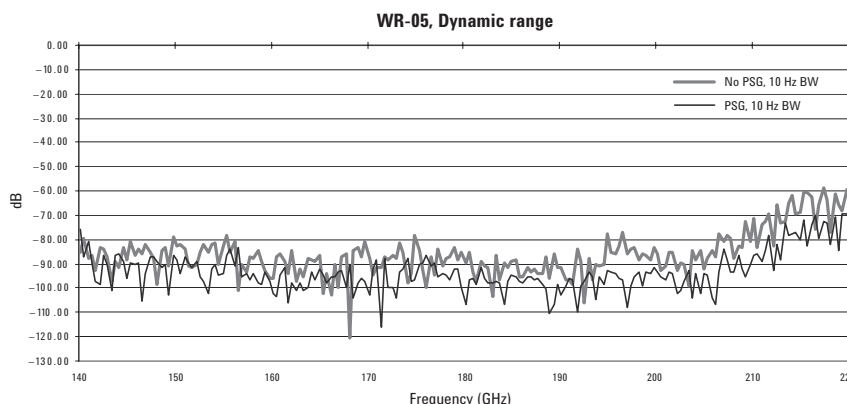

Figure 8. Dynamic range⁴ of frequency band WR-05 (140 to 220 GHz), PNA System with and without external synthesizers³.

Figure 9 illustrates achievable dynamic range from 220 to 325 GHz (WR-03 waveguide band). By adding external synthesizers to the PNA setup, an improvement of up to 20 dB is achievable, resulting in better than 60 dB in dynamic range across the entire frequency band, which is similar to that of the PNA-X (without external synthesizer). For additional details and millimeter-wave configuration information refer to Application Note 1408-15: *Banded Millimeter-Wave Measurements with the PNA*, literature number 5989-4098EN, found on the PNA Web page: www.agilent.com/find/pna.

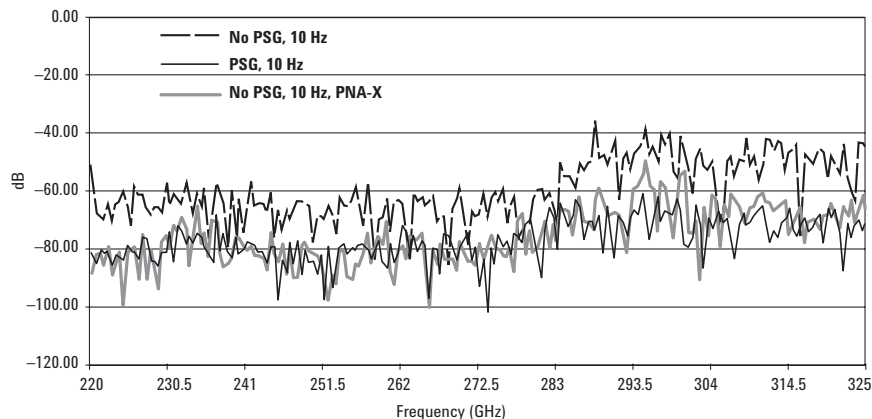

Figure 9. Dynamic range¹ of frequency band WR-03 (220 to 325 GHz), PNA system with and without external synthesizers² and PNA-X.

1. This plot is intended for use as a reference, and not as specifications. PNA system configuration included the E8362B 20 GHz MW PNA with Options H11, UNL, 014, 080 & 081, the N5260A mm-wave test set controller with one WR-03 Transmission/Reflection (T/R) test head module and one WR-03 Transmission-only (T) test head module. (One T/R module and one T module allow for S11 and S21 measurements. Two T/R modules allow for S11, S21, S12 and S22 measurements.) External synthesizers were added for dynamic range comparison. PNA-X system configuration included the N5242A with options 200 and 020, the N5260A millimeter-wave test set controller with one WR-03 T/R module and one WR-03 T module. Measurement setup: 201 points, 10 Hz IF BW, and no average.
2. External synthesizers used are the Agilent PSG Series, E8257D with Options 520 (20 GHz) and UNX (Ultra-low Phase Noise). Two external synthesizers are required; one for the RF signal and the other for the LO signal.
3. The following Microwave PNA's are compatible: E8361A, E8362B/3B/4B; each unit must include Options H11, 014, UNL, 080 and 081. PNA-X configuration includes N5242A with Options 200 and 020.
4. External synthesizers can be added to the PNA system as desired.

The PNA banded millimeter-wave system can also be configured for on-wafer applications. Waveguide probing accessories are available from Cascade Microtech, including Impedance Standard Substrates (ISS) for waveguide probes. Figure 10 shows the waveguide version of Cascade's Infinity probe to 220 GHz.



Figure 10. Cascade Infinity Probe (GSG 150), waveguide versions to 220 GHz.

Flexibility

The PNA banded millimeter-wave systems offer exceptional performance with ultimate system flexibility. A banded millimeter-wave system can be configured from the N5250A 110 GHz system by simply replacing the test head modules with the waveguide modules of your choice. A banded millimeter-wave system can also be configured from any of the Microwave PNA Series³ or the PNA-X by simply adding the N5260A millimeter-wave test set controller and a pair of waveguide band test head modules⁴.

Ease-of-use

The banded millimeter-wave system uses the standard PNA firmware, allowing you to: leverage software between PNA Series network analyzers, regardless of the frequency range of your measurement; manually control the instrument, using either the front panel or a mouse to access the simple pull-down menus; and utilize the Cal Wizard, which will guide you step-by-step through the most complicated of calibrations.

The banded millimeter-wave system can easily be configured using the dialogue box shown in Figure 11. Multiple system configurations can be added to the list, but only one is active at a time. Creating a banded configuration is easy, simply enter the start and stop frequencies, and the multipliers for RF and LO frequency ranges (the values can be located on the test head modules). Once a configuration has been added to the list, simply highlight the setup of choice and then click on "Activate Selected Config" to apply.

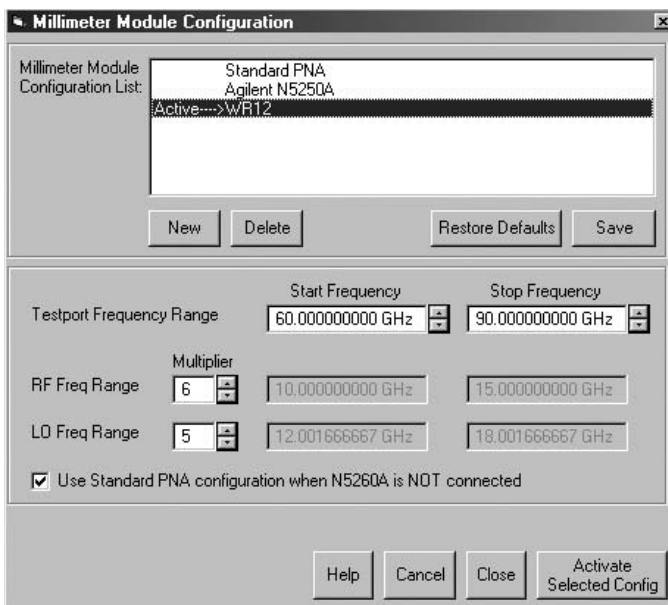

Figure 11. On-screen dialog box to configure a banded millimeter-wave setup.

In addition, an extensive, context-sensitive Help system thoroughly explains all of the PNA's features. In any dialog box, simply click on the "Help" button to see a detailed explanation of the feature you are using. Programming examples in both SCPI and COM are also included.

Connectivity

Windows built-in operating system and familiar user interface provides both ease-of-use and connectivity.

- Capture images quickly, easily and in .jpg, .bmp, and .png formats for easy data analysis, archiving, and printing.
- Control the analyzer using SCPI commands or gain the speed and connectivity advantage of COM/DCOM.
- Develop code in programming environments such as Visual Basic, Visual Basic.NET, Visual C++, Visual C++.NET, Agilent-VEE, or LabView.
- Execute code directly from the analyzer or remotely with an external PC through LAN or GPIB, or multiple USB ports.
- Use multiple USB ports to control a variety of peripherals.

The PNA millimeter-wave series and the entire series of microwave PNA instruments are based on the Windows® XP operating system, which makes operation and programming simple, and provides a powerful environment in which easy-to-use measurement functions and PC capabilities are seamlessly linked.

Banded millimeter-wave block diagram

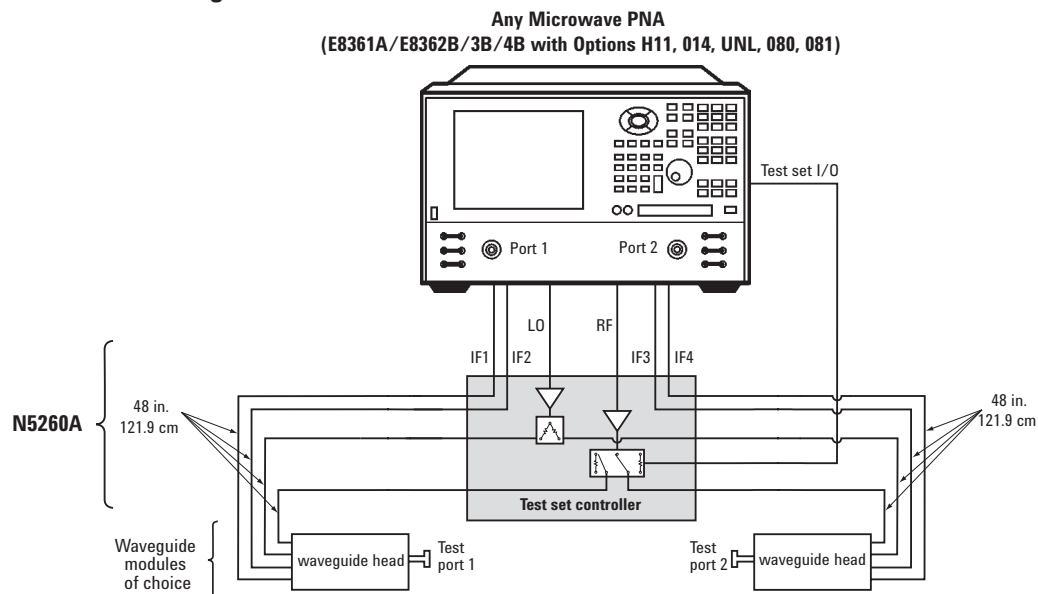

Figure 12. A banded millimeter-wave system consists of three major components:
 (1) Microwave PNA (E8361A/E8362B/3B/4B with Options H11, 014, UNL, 080, 081)
 or PNA-X (N5242A with Options 200 and 020), (2) N5260A and (3) Test head modules.

N5250A Ordering Information

With the N5250A, you receive all of the features and flexibility of the PNA platform, including:

- Windows architecture
- LAN, GPIB, and multiple USB ports
- 29 IFBW settings, 32 channels, 64 traces, and 20,001 points per trace
- Frequency converter measurements¹, pulsed-RF measurements¹, and time-domain transform applications

N5250A Configuration *(block diagram detail shown in Figure 5)*

- E8361A PNA microwave network analyzer which supplies the signal for frequencies up to 67 GHz
- Millimeter-wave test set controller drives the millimeter-wave test heads for performance up to 110 GHz
- The combiner assembly contains a 67 GHz coupler and a combiner that combines the 10 MHz to 67 GHz signal from the PNA with the 67 GHz to 110 GHz signal from the millimeter-wave test heads. Option 017 allows you to add bias-tees to the combiner assembly for added measurement stability for on-wafer and in-fixture devices.
- Millimeter-wave test heads provide the signal from 67 GHz to 110 GHz
- Miscellaneous cables

1. Up to 67 GHz.

N5250A PNA millimeter-wave system, 10 MHz to 110 GHz, includes:*E8361A MW PNA with IF access (Option H11)*

- Configurable test set – Option 014 (required)
- Extended power range and bias-tees – Option UNL (required)
- Frequency-offset mode – Option 080 (required)
- Reference channel switch – Option 081 (required)

N5260A millimeter-wave test set controller with test heads

- 67 GHz to 110 GHz test heads, micrometer attenuator on port 1
- 1.0 mm combiner assembly
- Interconnecting cables

Installation and productivity assistance (requires a completed ISP at order)

Additional options available:

- Millimeter-wave modules with bias-tees – Option 017
- Millimeter-wave modules with bias-tees and port 2 attenuator – Option 018
- Receiver attenuator up to 67 GHz – Option 016
- Time-domain capability – Option 010
- Pulsed-RF measurement capability – Option H08²
- Frequency converter application – Option 083²

Factory integration of the N5250A system integrates the E8361A with Option H11 and the N5260A millimeter-wave test set controller with test heads. On-site installation is included, and the entire system carries a full one-year, on-site warranty (where available).

Accessories

On-wafer applications

For on-wafer applications, Cascade Microtech provides complete probing systems using the N5250A and other PNA configurations. These include both new probing systems and upgrades to existing Cascade Microtech products. Cascade can also provide on-wafer verification and probing system training. Once the N5250A system is verified in coax, Cascade Microtech will verify the system through its wafer probes.

1.0 mm accessories

The following accessories are available for use with the N5250A system, but are not included in the system.

- 11500I 1.0 mm (f-f) test port cable (8.8 cm)
- 11500J 1.0 mm (m-f) test port cable (16.0 cm)¹
- 11500K 1.0 mm (m-f) test port cable (20.0 cm)¹
- 11500L 1.0 mm (m-f) test port cable (24.0 cm)¹
- 85059A DC to 110 GHz precision calibration/verification kit
- V281C 1.0 mm (f) to V-band waveguide adapter
- V281D 1.0 mm (m) to V-band waveguide adapter
- W281C 1.0 mm (f) to W-band waveguide adapter
- W281D 1.0 mm (m) to W-band waveguide adapter
- 11920A 1.0 mm (m) to 1.0 mm (m) adapter
- 11920B 1.0 mm (f) to 1.0 mm (f) adapter
- 11920C 1.0 mm (m) to 1.0 mm (f) adapter
- 11921E 1.0 mm (m) to 1.85² mm (m) adapter
- 11921F 1.0 mm (f) to 1.85² mm (f) adapter
- 11921G 1.0 mm (m) to 1.85² mm (f) adapter
- 11921H 1.0 mm (f) to 1.85² mm (m) adapter
- 11922A 1.0 mm (m) to 2.4 mm (m) adapter
- 11922B 1.0 mm (f) to 2.4 mm (f) adapter
- 11922C 1.0 mm (m) to 2.4 mm (f) adapter
- 11922D 1.0 mm (f) to 2.4 mm (m) adapter
- 11923A 1.0 mm (f) connector launch assembly

1. For on-wafer applications, two 11500J/K/L cables are required; one cable for each test port.

2. Frequency up to 67 GHz.

Available separately

E8361A MW PNA with the following options:

- IF access – Option H11 (required)
- Configurable test set – Option 014 (required)
- Extended power range and bias-tees – Option UNL (required)
- Frequency-offset mode – Option 080 (required)
- Reference channel switch – Option 081 (required)

Additional options available:

- Receiver attenuator up to 67 GHz – Option 016
- Time-domain capability – Option 010
- Pulsed-RF measurement capability – Option H08
- Frequency converter application – Option 083

In the future, when you require single sweep measurements up to 110 GHz, you can purchase the N5260A millimeter-wave controller with test heads separately to complete the system.

N5260A millimeter-wave test set controller, includes:

- Millimeter-wave test set controller
- Interconnecting cables

Note: PNA-X requires a set of 4 BNC-SMA adapters and a 10 dB pad for use with the N5260A.

Additional options available: (choose one, if applicable)

The following options include installation and productivity assistance – requires a complete ISP at time of order.

- Option 110 adds 67 GHz to 110 GHz test heads with combiner assembly, and port 1 attenuator.
- Option 120 adds 67 GHz to 110 GHz test heads with combiner assembly, port 1 attenuator and bias-tees.
- Option 130 adds 67 GHz to 110 GHz test heads with combiner assembly, bias-tees, ports 1 and 2 attenuators.

Note: Option PS-S20 Productivity assistance recommended when Option 110, 120, or 130 is NOT ordered.

N5260A banded system ordering information

Each banded millimeter-wave configuration must consist of three main components: (1) the receiver, (2) the test set controller, (3) the waveguide test head modules. The fourth component, external synthesizers, may not be necessary for lower frequency bands or the PNA-X, but are recommended for the PNA with operations above 110 GHz and are required for operations at and above 220 GHz.

Banded millimeter-wave solutions								
System configurations	WR-15 50-75 GHz	WR-12 60-90 GHz	WR-10 75-110 GHz	WR-08 90-140 GHz	WR-06 110-170 GHz	WR-05 140-220 GHz	WR-03 220-325 GHz	WR-02.2 ¹ 325-500 GHz
Receiver (choose one)	<ul style="list-style-type: none"> • Any Microwave PNA (E8361A/E8362B/3B/4B with Options H11, 014, UNL, 080, 081) • PNA-X (N5242A with Options 200 and 020) 							
Test set controller	N5260A							
Test head modules ²	N5260AW15	N5260AW12	N5260AW10	N5260AW08	N5260AW06	N5260AW05	N5260AW03	N5260AS02
External synthesizers ³				Recommended: E8257D with Options 520 and UNX (Qty of 2)			Required: E8257D with Options 520 and UNX (Qty of 2)	

1. When WR-02.2 is used with the N5260A test set, add an external 12V 3A power supply (eg., E3615A)

Option descriptions

- **Millimeter-wave modules with bias-tees (Option 017)**
(Only available with the PNA N5250A)
 Adds 67 GHz bias-tees to the combiner assembly between the input to the combiner and the 67 GHz coupler. The bias-tees have tri-axial connectors for force, sense, and ground. Positioning the bias-tees close to the DUT greatly improves stability for on-wafer and in-fixture devices. The bias-tees added for this option have a voltage rating of 40 volts and a maximum of 0.5 amps.
- **Millimeter-wave modules with bias-tees and port 2 attenuator (Option 018)**
(Only available with the PNA N5250A)
 Adds 67 GHz bias-tees to the combiner assembly between the input to the combiner and the 67 GHz coupler. The bias-tees have tri-axial connectors for force, sense, and ground. Positioning the bias-tees close to the DUT greatly improves stability for on-wafer and in-fixture devices. The bias-tees added for this option have a voltage rating of 40 volts and a maximum of 0.5 amps. Additionally, Option 018 adds a 25 dB micrometer attenuator to the port 2 test head.
- **IF access (Option H11)**
 Provides hardware to enable antenna, point-in-pulse, and broadband millimeter-wave measurements to 110 GHz. For each of the MW PNA's measurement receivers, IF gates (enabled with pulsed measurement capability, Option H08) and external IF inputs are added. In addition, access to the PNA's internal RF and LO source is provided for remote mixing applications. For basic antenna measurements, only Option H11 is necessary. Pulsed-antenna applications also require the pulsed measurement capability (Option H08). Broadband measurements to 110 GHz, also requires an N5260A.

 - Use external IF access for up to 20 dB more sensitivity when making antenna measurements with a remote mixing configuration
 - Add Option H08 (Pulsed-RF Measurement Capability) to enable advanced pulsed measurements
 - Upgrade an E8361A with Option H11 to a broadband (10 MHz to 110 GHz) VNA system simply by purchasing an N5260A controller test set with Option 110, 120, or 130.
- **Time-domain capability (Option 010)**
 Used for viewing reflection and transmission responses in time or distance domain.
- **Configurable test set (Option 014)**
 Provides six front panel access loops. The loops provide access to the signal path between (a) the source output and the reference receiver, (b) the source output and directional coupler thru arm and (c) the coupled arm of the directional coupler and the port receiver.
- **Extended power range and bias tees (Option UNL)¹**
 A 50 dB step attenuator and bias-tee set is inserted between the source and test port one and another set between the source and test port two.
- **Frequency offset (Option 080)¹**
 This option enables the PNA Series microwave network analyzers to set the source frequency independently from where the receivers are tuned.
- **Reference receiver switch (Option 081)**
 Option 081 adds a solid-state internal RF transfer switch in the R1 reference-receiver path. The switch allows the instrument to easily switch between standard S-parameter (non-frequency-offset) measurements and frequency-offset measurements such as relative phase or absolute group delay that require an external reference mixer.
- **Frequency converter measurement application (Option 083)¹**
 The frequency converter application adds an intuitive and easy-to-use user interface, advanced calibration choices that provide exceptional amplitude and phase accuracy, and control of external signal sources for use as local oscillators.

- **Add receiver attenuators (Option 016)¹**
A 50 dB step attenuator is added between each test port and its corresponding receiver.
- **Pulsed-RF measurement capability (Option H08)¹**
Provides software to set up and control pulsed-RF measurements with point-in-pulse capability. The software sets the coefficients of the MW PNA 's digital-IF filter to null out unwanted spectral components, enables the IF gates provided with IF Access (Option H11), and controls selected Agilent pulse generators. It can be run on the PNA or an external computer. A ".dll "file containing the IF-filter algorithms is included for automated pulsed-RF testing. The pulsed application is configured to work with the Agilent 81110A series pulse generator. For more detailed information regarding pulsed measurement capabilities with the PNA refer to the Agilent Web site www.agilent.com/find/pna and download the *PNA Series MW Configuration Guide for Pulsed Measurements*, literature number 5988-9833EN.
- **Rack mount kit without handles (Option 1CM)**
Adds a rack mount (5063-9217) and rail kit (E3663AC) for use without handles.
- **Rack mount kit with handles (Option 1CP)**
Adds rack mount (5063-9237) and rail kit (E3663AC) for use with previously supplied handles.

Test head modules

- The test head modules used in banded millimeter systems include a set of T/R VNA2 waveguide modules from OML, Inc. with a calibration kit.
- For frequency between 325 and 500 GHz you would need to order 2 of the N5260AS02 modules and the N5260AC02 calibration kit.
- 8510 based system test head modules are available through OML as VNA1 modules. Please contact OML, Inc for more details or visit the website at www.omlinc.com

External synthesizers

- Recommended for enhancement of dynamic range of systems in certain frequency bands of operation.
- Typically for operations below 110 GHz external synthesizers are not required to achieve the already exceptional dynamic range as stated in the table on Page 6.
- When using a PNA based system and if you need to improve the dynamic range by up to 10 dB a set of external synthesizers are recommended. Note you will not need the external synthesizers when using a PNA-X.
- For frequency bands beyond 220 GHz, an improvement of up to 20 dB may be gained for PNA based configurations. Once again on the PNA-X there is no need to add external sources, please refer to Figure 9 for the typical performance.
- For rack mount configurations a rear panel output is recommended.

Ordering external synthesizers (not required for N5242A PNA-X)

- Two external synthesizers are required one for the RF and one for the LO and we recommend the E8257D with options 520 and UNX.
- For rear panel access to the E8257D option 1EM is available, moves all front panel connector to the rear.
- When external synthesizers are added, the following cables are also required and may be purchased separately:
 - 5 x BNC (2 for 10 MHz connections and 3 for Trigger connections)
 - 2 x 3.5mm (11500 E/F depending on setup and distance)
 - 2 x GPIB (10833A 1 meter GPIB cable)

1. Up to 67 GHz.

PNA and PNA-X Options as related to banded millimeter-wave systems

	PNA series	PNA-X
	E8362B (10 MHz to 20 GHz) E8363B (10 MHz to 40 GHz) E8364B (10 MHz to 50 GHz) E8361A (10 MHz to 67 GHz)	N5242A (10 MHz to 26.5 GHz)
2-port with configurable test set	Option 014 ¹	Option 200 ²
4-port with configurable test set	n/a	Option 400
Time domain	Option 010	Option 010
IF access / IF inputs	Option H11 ¹ (requires Options 014, UNL, 080 and 081)	Option 020 ²
Built-in pulse modulators	n/a	Option 021 (first source) Option 022 (second source)
Built-in pulse generators	n/a	Option 025
Pulse measurements	Option H08	Option H08
Frequency offset	Option 080 ¹	Option 080
Reference receiver switch	Option 081 ¹	(included in Options 200 and 400)
Extended power range and bias tees	Option UNL ¹	Option 219 (2-port, requires Option 200) Option 419 (4-port, requires Option 400)

Please refer to the *Agilent PNA Series Microwave Network Analyzers Configuration Guide*, literature number 5988-7989EN, for details on option descriptions, other configurations and accessories.

1. Minimum requirement on the PNA configuration to be used in a banded millimeter-wave system: E8361A/E8362B/3B/4B with Options H11, 014, UNL, 080 and 081.
2. Minimum requirement on the PNA-X configuration to be used in a banded millimeter-wave system: N5242A with Options 200 and 020.

Key Web Resources

Engineering services for 8510 to PNA Series migration

Agilent's network analyzer experts can save you time and money by working with you to migrate your 8510 instruments and transition your test code quickly and easily. For more information visit: www.agilent.com/find/8510

Information resources

For more information on the N5250A PNA visit: www.agilent.com/find/pna

Test and measurement accessories visit: www.agilent.com/find/accessories

Agilent channel partners

Our channel partners offer accessories and measurement solutions that extend your network analysis capabilities.

For information about probing equipment and accessories, contact:

Cascade Microtech, Inc.
2430 NW 206th Avenue
Beaverton, Oregon 97006, USA
Toll-free telephone: (800) 550-3279
Telephone: (503) 601-1000
Fax: (503) 601-1002
Web site
www.cascademicrotech.com
E-mail: sales@cmicro.com

Remove all doubt

Our repair and calibration services will get your equipment back to you, performing like new, when promised. You will get full value out of your Agilent equipment throughout its life-time. Your equipment will be serviced by Agilent-trained technicians using the latest factory calibration procedures, automated repair diagnostics and genuine parts. You will always have the utmost confidence in your measurements.

Agilent offers a wide range of additional expert test and measurement services for your equipment, including initial start-up assistance onsite education and training, as well as design, system integration, and project management.

For more information on repair and calibration services, go to

www.agilent.com/find/removealldoubt



Agilent Email Updates

www.agilent.com/find/emailupdates
Get the latest information on the products and applications you select.



Agilent Direct

www.agilent.com/find/agilentdirect
Quickly choose and use your test equipment solutions with confidence.



www.agilent.com/find/open

Agilent Open simplifies the process of connecting and programming test systems to help engineers design, validate and manufacture electronic products. Agilent offers open connectivity for a broad range of system-ready instruments, open industry software, PC-standard I/O and global support, which are combined to more easily integrate test system development.

www.agilent.com

For more information on Agilent Technologies' products, applications or services, please contact your local Agilent office. The complete list is available at: www.agilent.com/find/contactus

Americas

Canada	877 894 4414
Latin America	305 269 7500
United States	800 829 4444

Asia Pacific

Australia	1 800 629 485
China	800 810 0189
Hong Kong	800 938 693
India	1 800 112 929
Japan	81 426 56 7832
Korea	080 769 0800
Malaysia	1 800 888 848
Singapore	1 800 375 8100
Taiwan	0800 047 866
Thailand	1 800 226 008

Europe

Austria	0820 87 44 11
Belgium	32 (0) 2 404 93 40
Denmark	45 70 13 15 15
Finland	358 (0) 10 855 2100
France	0825 010 700 *0.125€ fixed network rates
Germany	01805 24 6333* *0.14€/minute
Ireland	1890 924 204
Israel	972 3 9288 504/544
Italy	39 02 92 60 8484
Netherlands	31 (0) 20 547 2111
Spain	34 (91) 631 3300
Sweden	0200-88 22 55
Switzerland (French)	41 (21) 8113811 (Opt 2)
Switzerland (German)	0800 80 53 53 (Opt 1)
United Kingdom	44 (0) 118 9276201

Other European Countries:
www.agilent.com/find/contactus
Revised: October 24, 2007

Windows, Windows 2000 and VisualBasic are U.S. registered trademarks of Microsoft Corporation.

Product specifications and descriptions in this document subject to change without notice.

© Agilent Technologies, Inc. 2007, 2008
Printed in USA, March 26, 2008
5988-9620EN

